

Ceramic Lined Double Mechanical Seal Centrifugal Pump

Efficient - Non-Corroding - Abrasion-Resistant



ET

Double mechanical seal chemical process pump

Designed to:
DIN EN ISO 2858 and 5199

Compliant with:
EC Directives 2006/42/EC (Machinery) and 2014/34/EC (ATEX)

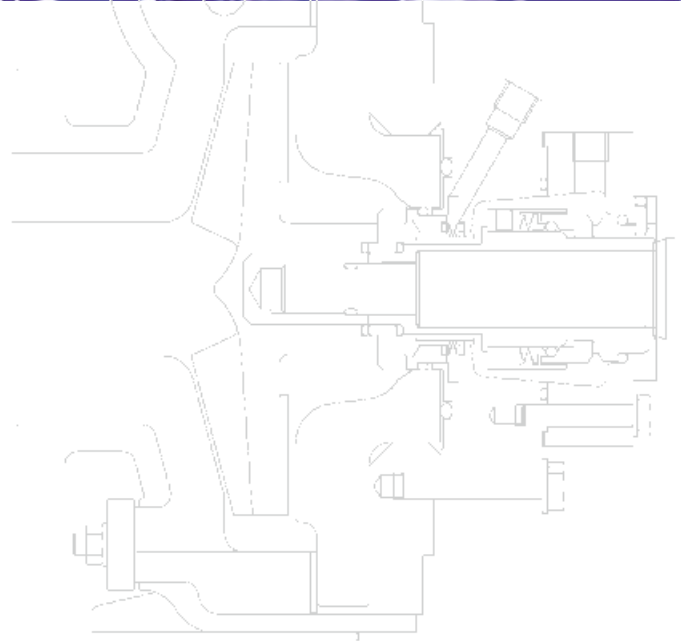



Open impeller of the ceramic lined double mechanical seal chemical process pump



CP Pump Systems

Ceramic Lined Double Mechanical Seal Chemical Process Pump

Our company

CP is a highly innovative Swiss company with a rich tradition. For over 60 years, we have specialised in developing and manufacturing premium quality high-tech products and providing services for international customers with the most rigorous requirements.

We produce reliable and innovative centrifugal pumps for the chemical, pharmaceutical, biotechnology, food and beverage, and pulp and paper industries. Through our network of representatives in more than 40 countries, we offer first-class advice and ensure efficient customer service locally, around the world.

Reflecting our deep commitment to energy efficient products and services, we deliver environmentally friendly solutions that always go hand in hand with maximum safety and economy. As a pioneer in this area, we advise and assist customers with a wide range of needs – throughout the value chain.

CP operates a quality management system certified to ISO 9001:2008.

Energy efficiency in industry

Nowadays, industry is facing increasing demands to improve sustainability and energy efficiency. Pumps are considered to play a key role because they offer vast potential to save energy and costs. Already recognising this back in 1999, CP took action and has become a pioneer in energy-saving pumping systems.

In recent years, we have continuously enhanced the hydraulic performance of numerous pump systems, increasing their efficiency by up to 30 per cent. At the same time, we have steadily improved pump safety, a mission we have vigorously pursued ever since our company was established in 1948.

We are wholeheartedly committed to promoting sustainable manufacturing in industry around the world. Our customers benefit from a comprehensive range of solutions that reduce costs and CO₂ emissions over the long term. Cleaner pumps, cleaner planet: we firmly believe that sustainable research, thinking and action always pay off for everyone.

Ceramic lined double mechanical seal chemical process pump

Fitted with a double mechanical seal as standard, the ET pump is ideal to meet the stringent requirements of chemical processing and a multitude of other industries. This highly advanced and extremely energy efficient pump is built for reliability and absolute safety in handling a huge variety of corrosive and abrasive fluids with a high solids content.

The pump has a thick, heavy-duty, abrasion-, corrosion- and permeation-resistant ceramic lining securely attached to the metal casing. Use of engineering ceramic gives the ET outstanding chemical resistance.

For reliable handling of fluids containing solids, the ET features a non-clog, wear-resistant open impeller that delivers low NPSH and superior efficiency. The impeller clearance can be adjusted easily and accurately to maximise efficiency.

The ET is designed as a modular system constructed with very robust components. Its pump shaft is supported by an oil-lubricated bearing frame.

This pump's connection dimensions and performance data conform to DIN EN ISO 2858, making the ET easy to retrofit into any installation to replace old pumps.

Technical Information

Technical data

Capacities (min./max.)	0.5 to 300 m ³ /h
Heads (min./max.)	3 to 70 m
Temperatures (min./max.)	-20°C to +150°C
Kinematic viscosities	0.5 to 350 mm ² /s
Solids handling	highly suitable

Directives

EC Directive 2006/42/EC (Machinery)
 EC Directive 2014/34/EC (ATEX)

Standards

DIN EN ISO 2858
 DIN EN ISO 5199

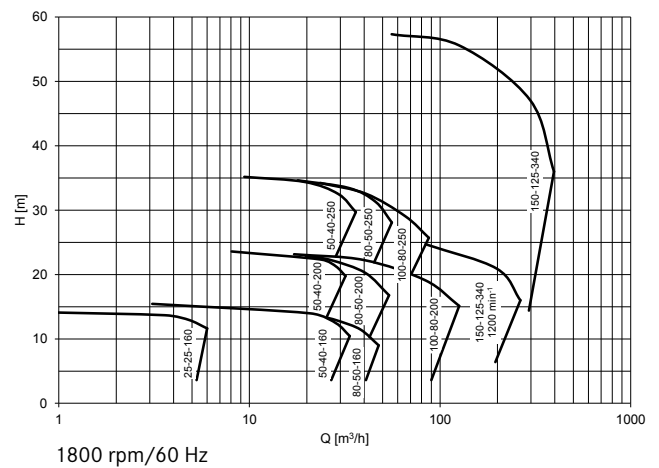
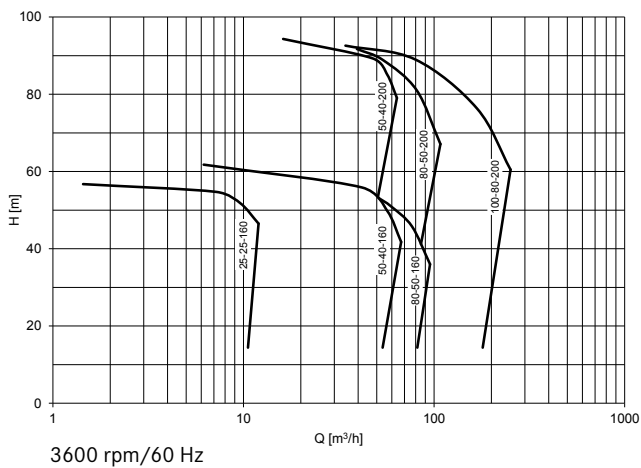
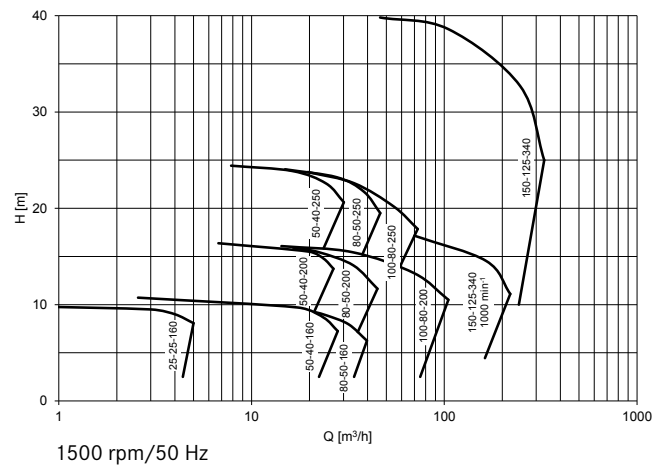
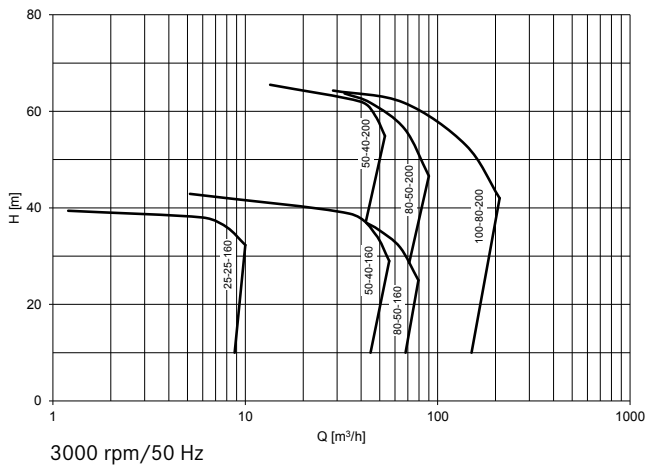

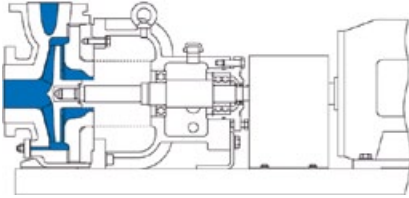

Frame-mounted ET
with baseplate
-20°C to +150°C

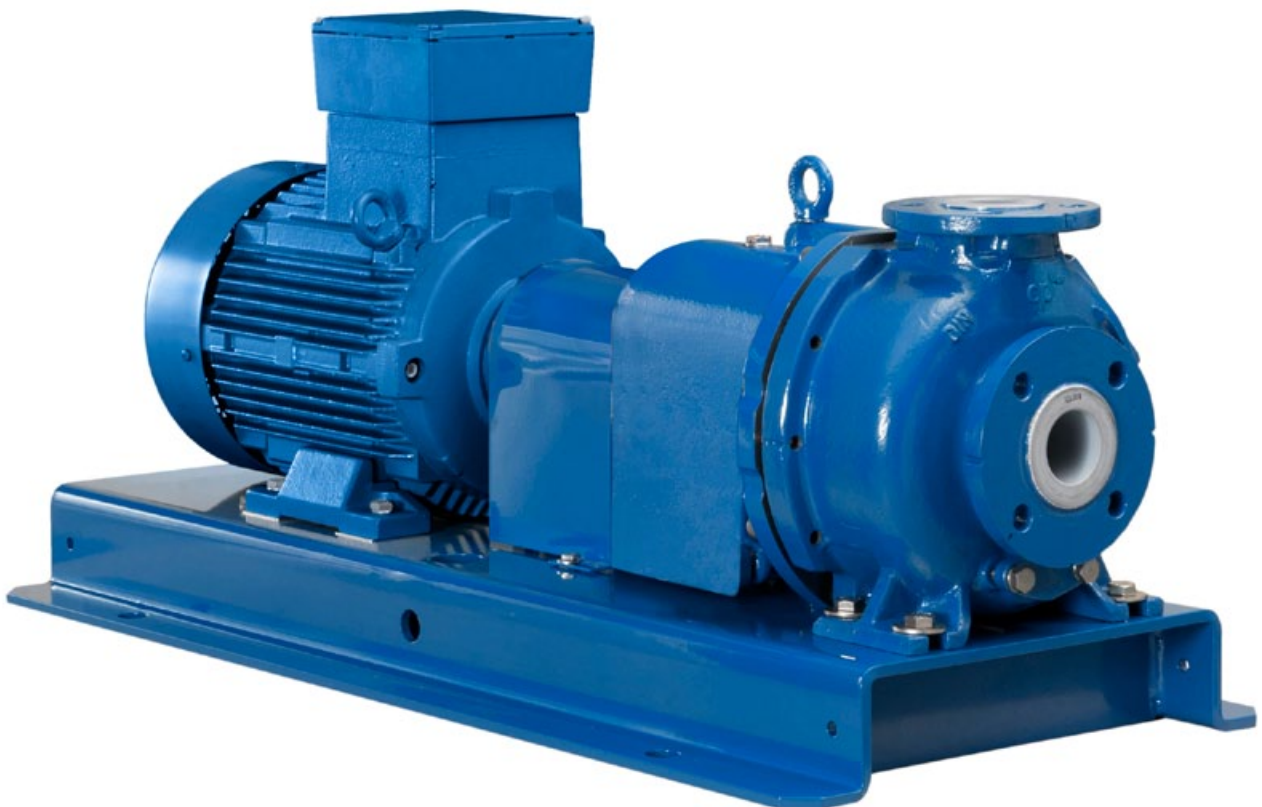

ET with baseplate and motor
horizontal frame-mounted (-20°C to +150°C)

Options

Comprehensive – Individual – Combinable

Casing

Material

– Ceramic lined cast iron

Pressure rating

– PN 11*

Connection flanges

– Flange to EN 1092-2

– Flange drilled to ANSI/ASME B16.5

Additional connections

– Casing drain (with or without flange)

– Mechanical seal housing drain/vent

Gasket materials

– PTFE-enveloped

– FKM

– Gylon® blue

Casing wear ring

*Maximum, varies depending on the pump size.



Mechanical seal

FuturaMik® double mechanical seal

Standard double mechanical seal

Standard single mechanical seal



Shaft sleeve



Double mechanical seal barrier/buffer fluid vessel

Vessel

- Cooling coil, manometer, thermometer and sight glass
- Total volume from 3 to 12 l (depending on vessel type)
- Hand refill pump (depending on vessel type)

Vessel connections

- Stainless steel braided PTFE hose
- Stainless steel piping

Brackets

- Steel
- Stainless steel



Pump protection

Barrier/buffer fluid monitoring

- Level switch
- Pressure switch
- Temperature probe

Motor load sensor



Mount

Type

- Baseplate

Materials

- Steel
- Stainless steel

Stilts

Drip pan



Bearing frame

Lubrication

- Oil lubrication

Oil lubrication options

- Constant level oiler

Coupling

Coupling guard

- Steel
- Brass

Sectional View

ET

horizontal frame-mounted (-20°C to +150°C)

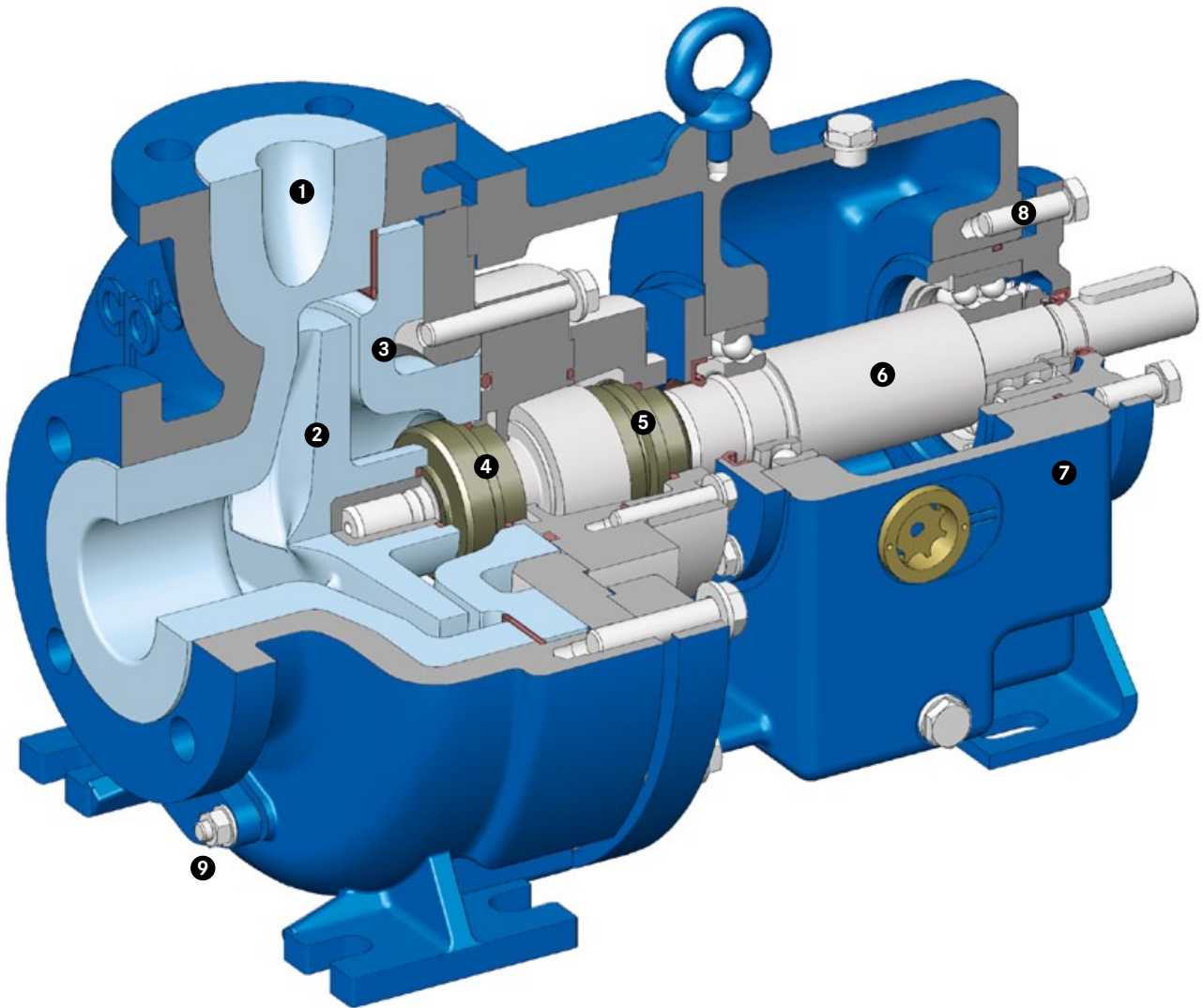

- 1 Pump casing with ceramic lining
- 2 Impeller
- 3 Ceramic lined casing cover
- 4 Seal faces (on product side)
- 5 Seal faces (on atmospheric side)

- 6 Pump shaft
- 7 Oil-lubricated bearing frame
- 8 Impeller clearance adjusting bolt
- 9 Casing drain



Doubly Effective – FuturaMik®

The FuturaMik® double mechanical seal is particularly well suited for challenging applications, especially in the chemical industry. First launched on the market in 1998, it has since been continuously enhanced to meet the growing demands of industry, while retaining all of its versatility and efficiency.

Designed for an impressively wide range of applications, it is:

- Ideal for sealing corrosive, solids-laden and abrasive media
- Highly suitable for ceramic lined chemical process pumps
- Universally chemically resistant, having no wetted metal parts

Outstanding features are its safety mechanisms:

- Springs protected from the pumped medium
- Double seal remaining closed in the event of barrier fluid pressure loss
- Shaft sleeve to protect the shaft from damage

System for sealing integrity

The FuturaMik® is a double mechanical sealing system featuring high-grade ceramic (SSiC) seal faces and a metallic shaft sleeve for zero leakage. The spring assembly never comes into contact with the pumped medium. A barrier fluid in the mechanical seal lubricates the seal faces and simultaneously provides sealing integrity, preventing both the springs and the O-ring located on the atmospheric side from clogging or sticking. As a result, the pressure on the seal face is always maintained, ensuring that the seal operates reliably.

Consisting of few parts, the FuturaMik® is easy to install and requires no adjustments. SSiC (sintered silicon carbide) against SSiC is exclusively used as the seal material on the product side, while other seal face combinations are available on the atmospheric side. This allows the FuturaMik® to be configured for virtually any special application.

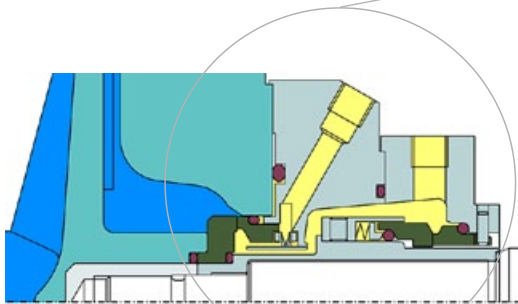

**FuturaMik®
double mechanical seal**

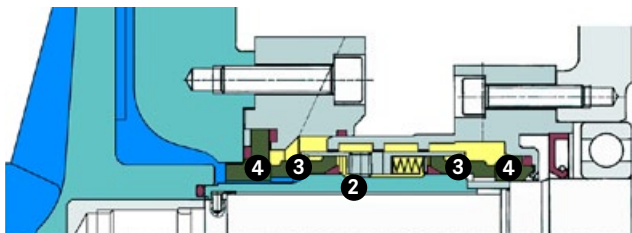
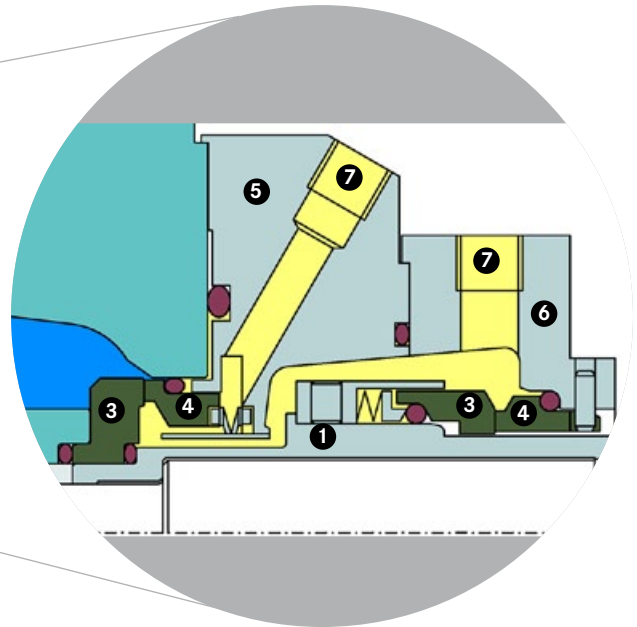

**Back-to-back
double mechanical seal**

- 1 Metallic shaft sleeve
- 2 Ceramic shaft sleeve
- 3 Rotating seal ring
- 4 Stationary seal ring
- 5 Seal cover
- 6 Shaft seal housing
- 7 Flush connections

Applications

Versatile – Complex – Special

CP's ceramic lined double mechanical seal centrifugal pump is engineered to meet the most stringent quality standards and ensure reliability and utmost safety in production operations. Suitable for many different fluids in a variety of industries and processes, it is capable of handling low, medium and high flow volumes. The ET chemical process pump from CP offers tremendous advantages, especially in pumping very sensitive or hazardous substances.

Industries

- Chemical processing: basic and fine chemicals (agrochemicals, speciality chemicals)
- Pharmaceuticals
- Biotechnology processing
- Food and beverages
- Pulp and paper

Processes

CP's ceramic lined double mechanical seal centrifugal pump is designed for a wide range of processes, including:

- MDI processes
- TDI processes
- Titanium dioxide manufacturing

Fluids

CP's ceramic lined double mechanical seal centrifugal pump can handle acids, bases, solvents, suspensions and fluids containing abrasives. For example:

- Acetone
- Aluminium chloride
- Aniline
- Diaminodiphenylmethane
- Dichloromethane
- Hydrochloric acid
- Sulphuric acid
- Titanium dioxide
- Toluene
- Zinc compounds

Our sales staff will be glad to give you personalised advice tailored to your specific needs, industry, processes and fluids.





CP Pump Systems

Our Product Portfolio

Customer service

We offer the highest quality, many years of experience and first-class advice from a single source. Our bespoke pump systems meet a wide range of different requirements.

CP's customers benefit from a full service offering: the fastest availability of genuine spare parts, a complete set of technical documentation, competent and efficient customer support, and a dynamic and flexible repair service. All these services ensure that your pumps will operate faultlessly. Having representatives in more than 40 countries, we can provide local advice and support directly to our customers where required.

Energy efficiency consulting

As a trend scout specialised in energy efficiency, CP can deliver a wide spectrum of services relating to pumps and motors: comprehensive advice, in-depth system analysis, meticulous planning and design. Our goal is to actively help our customers optimise the energy consumption of their pumping systems and thereby cut costs over the long term.

Backed by our many years of broad experience, we today advise and assist customers in both the private and public sectors. These include owners and operators of fluid processing plants in the chemical, pharmaceutical and diverse other industries.

Are you interested? Do you have any questions? We would be happy to discuss all the different options with you personally.

Stainless steel magnetic drive centrifugal pumps

MKP

Magnetic drive chemical process pump

MKP-S

Self-priming magnetic drive chemical process pump

MKTP

Magnetic drive chemical process sump pump

MKP-ANSI

Magnetic drive chemical process pump

MKPP

Magnetic drive in-line chemical process peripheral pump

SZMK

Magnetic drive in-line chemical process pump

Stainless steel magnetic drive biotech process pump

MKP-Bio

Magnetic drive centrifugal pump for sterile processes

PFA lined magnetic drive centrifugal pumps

MKPL

Magnetic drive chemical process pump

MKPL-S

Self-priming magnetic drive chemical process pump

Solid PTFE magnetic drive centrifugal pumps

MSKP

Magnetic drive chemical process pump

MSKPP

Magnetic drive chemical process peripheral pump

MSKS

Self-priming magnetic drive chemical process side channel pump

Stainless steel mechanical seal centrifugal pumps

IL-BTO

In-line mechanical seal chemical process pump

KTP

Multi-stage mechanical seal chemical process sump pump

ZMP

Mechanical seal chemical process grinder pump

PFA lined double mechanical seal centrifugal pump

EB

Double mechanical seal chemical process pump

Ceramic lined double mechanical seal centrifugal pump

ET

Double mechanical seal chemical process pump



Improving energy efficiency in pumping systems helps to create a cleaner planet.

Your CP distributor



A-PF Solutions s.r.l.

+32 (0)478 29 26 69

info@apfs.be

www.apfs.be

ClimatePartner^o
climate neutral



Follow us on:

