



Centrifugal Pumps



CN series

Standard design

Closed coupled single-stage centrifugal pumps. A range of 3 models with open impellers, independent shafts and IEC standard motors.

Optimised design to ensure high levels of hygiene - The absence of product hold-up and no dead-legs ensures efficient cleaning by standard CIP methods and effective sterilisation by SIP.

Wetted parts are in pressed polished plate and investment cast electropolished CF3M 1.4409 / AISI 316L (1.4404) stainless steel.

Investment cast and electro-chemical polishing. Internal finishes of 0,5 micron Ra are available on request..

Flow rates up to 75 m³/h, heads of more than 60 m.
Maximum inlet pressure : 4 bar.
Temperature range: -10°C to 120°C.



Pump with shroud and stainless steel adjustable feet.



Pump without shroud and stainless steel motor shims.



Open impeller with reversed blades with vast expansion designed to optimize the hydraulic efficiency.

Seals:

Hygienic mechanical seals with seats to EN 12756, ISO 3069 standards.

Elastomers (US FDA):

- EPDM
- Fluorocarbon (Viton)
- Silicone
- P.T.F.E. (FEP)

Connections:

DIN - SMS - IDF - BS / RJT - DS - CLAMP and EN 1092-1 PN16 flanges and on request available for other international standards.

Applications

Food processing, dairy, beverage, chemical, cosmetics and pharmaceutical industries. The open impeller allows a large range of products such as purified water, juices, creams, ice-cream mix, milk, wine, spirits, whey and WFI to be safely transferred.



GENERAL DIAGRAMS

Performance applies to H₂O at 20 °C, 1013 mbar Data not binding

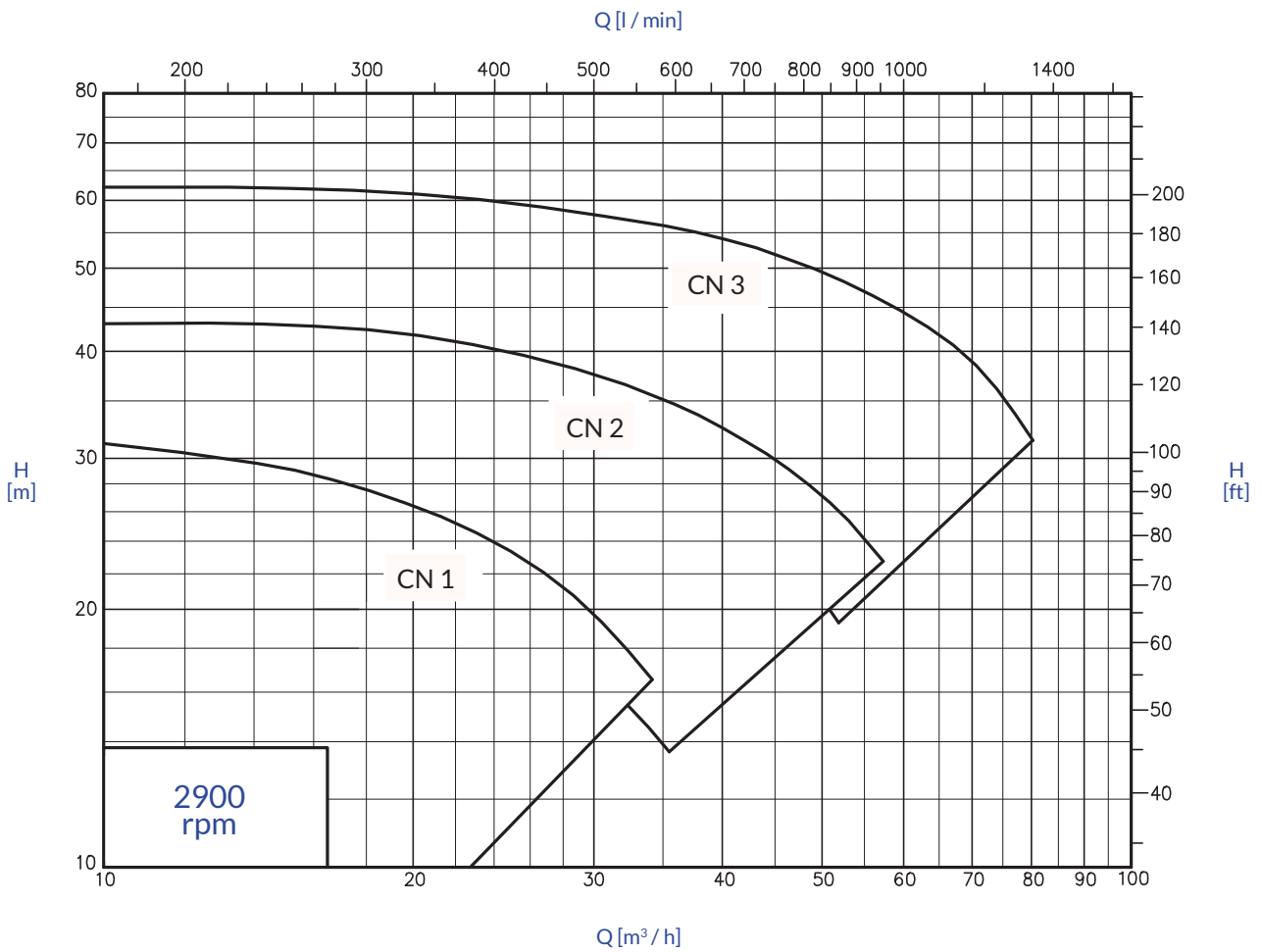
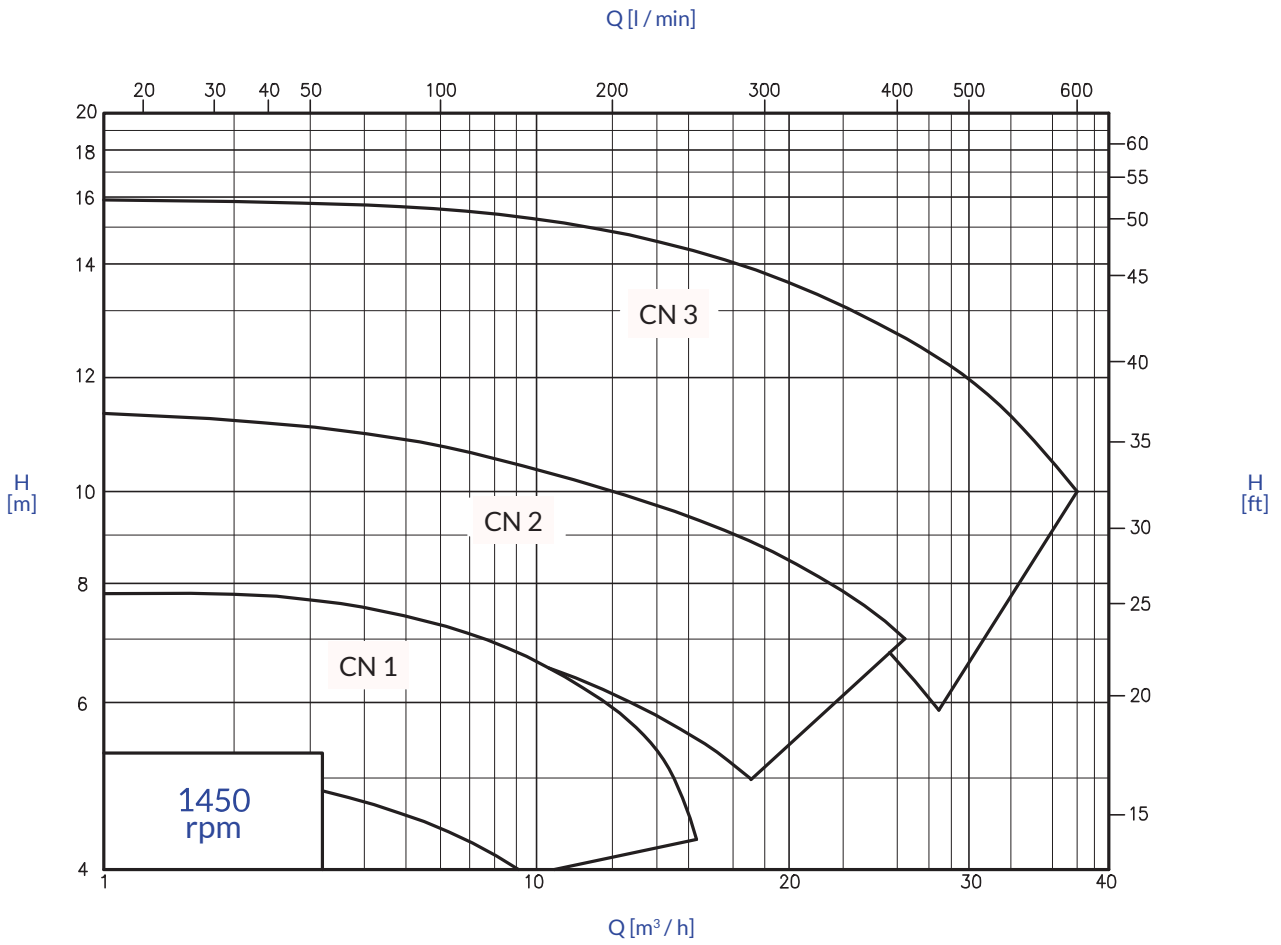

All stainless construction, with standard motor, separate pump shaft with clamp coupling, internal product seal and an open impeller.



The clamp casing and seal design allow quick disassembly for inspection, cleaning and maintenance. It also enables the delivery port to be rotated to any position for easy installation and drainage.
Motor shroud.

OVERALL DIMENSIONS

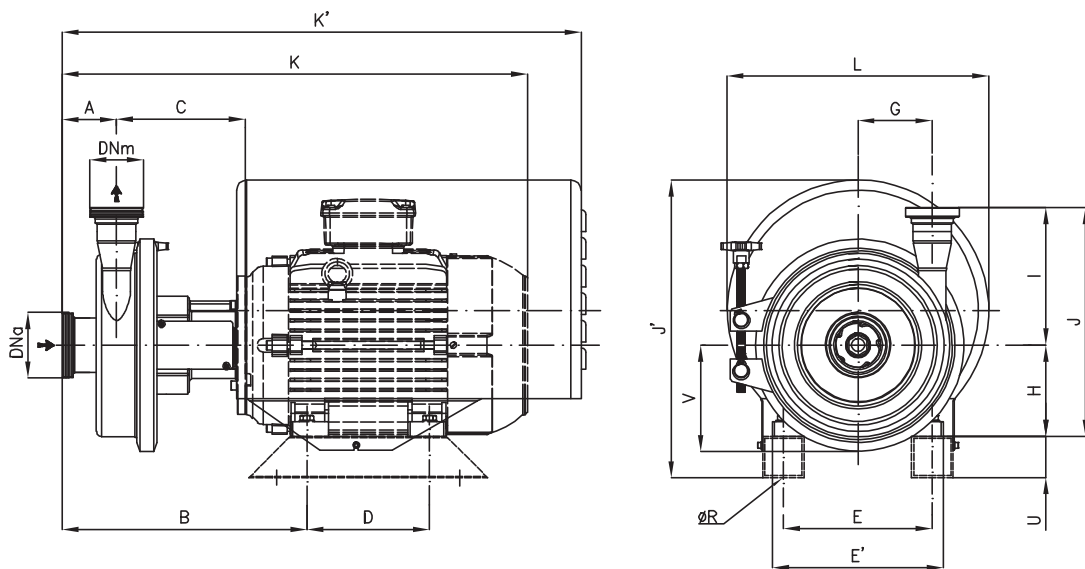

Dimensions not binding - DN = DIN 11851 male threaded connections with standard IEC/EN motors

Pumps	IEC motors size:	DNa	DNm	A	B	C	D	E	E'	G	H	K	K'	ØR	I	J	J'	L	U	V					
CN 1	80	50	40	73	277	153,5	100	125	155	86	80	463	584	10	183	263	286	303	40	127					
	90				282,5			140	165		90	501	597			273	318								
	100				319,5			140	160		196	100	572			673	283				389	369	50		
	112				183,5			178	216		256	112	591			744	295				402	315	412	380	60
	132 S							357,5	190		226	132	627			744	315				412	380	60		
CN 2	80	65	50	79	286	157	100	125	155	108	80	472	593	10	200	280	286	303	40	154					
	90 S				292		140	165	90		508	606	290			317									
	90 L				187		125	160	196		100	580	683			300	388				369	50			
	100						140	190	226		112	598	753			312	400								
	112				329		140	190	226		132	635	753			332	432				380	60			
	132 S				355		178	216	256		160	778	911			360	528				473	50			
	132 M				404		217	254	300		160	778	911			360	528				473	50			
160	404	217	254	300	160	778	911	360	528	473	50														
CN 3	90 S	80	65	81	296	159	100	140	164	129	90	519	609	10	255	345	318	303	40	179					
	90 L				125		160		100		585	687					369				50				
	100				189		140	190			112	604	687												
	112						140	190			112	604	687												
	132 S				358,5		188,5	140	216		256	132	640			757	12				387	432	380	60	
	132 M				407,5		218,5	178	254		300	160	784			915	15				415	588	473	50	

OVERALL DIMENSIONS

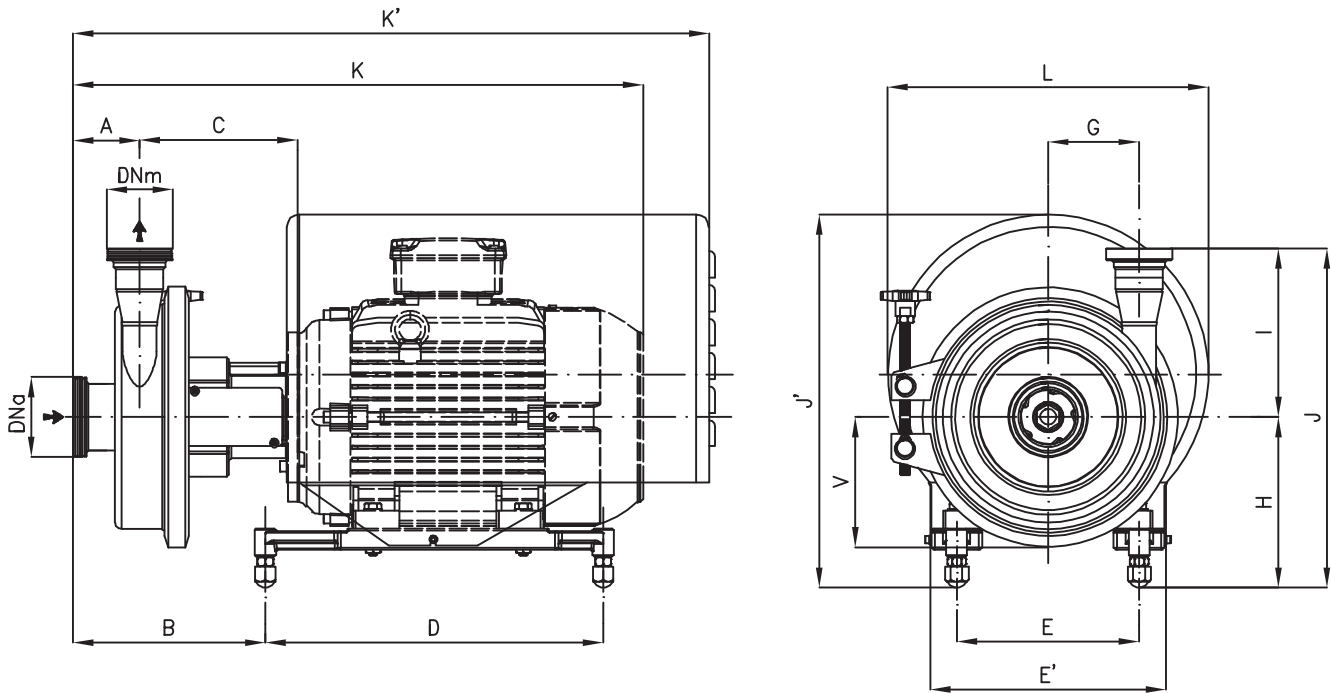

Dimensions not binding - DN = DIN 11851 male threaded connections with standard IEC/EN motors

Pumps	IEC motors size:	DNa	DNm	A	B	C	D	E	E'	G	H	K	K'	I	J	J'	L	V	
CN 1	80	50	40	73	210	153,5	270	138	213	86	160	463	584	183	350	333	303	127	
	90											501	597		343	348	303		
	100											170	572		673	353	409		369
	112											182	591		744	365	422		380
	132 S											202	627		744	385	425		380
CN 2	80	65	50	79	219	157	270	140	213	108	185	472	593	200	367	333	303	154	
	90											508	606		385	372	303		
	100											194	580		683	394	433		369
	112											206	598		753	406	445		380
	132 S											202	635		753	402	442		380
	132 M											202	673		753	402	442		380
CN 3	90	80	65	81	223	159	270	140	213	129	185	519	609	255	438	372	303	179	
	100											585	687		449	433	369		
	112											205	604		687	460	433		369
	132 S											227	640		757	482	467		380
	132 M											227	678		757	482	467		380
	160											211	784		915	466	528		473