



Centrifugal Sanitary Pumps



CL-CLC series

Standard design

Available in a wide range of models with closed or open impellers and 2 or 4 pole motors, this well-established series of hygienic pumps can perform an amazing number of applications. The special construction with hand-nuts & clamps allows easy disassembly for inspection and cleaning of the internal components

Wetted parts are in forged polished plate and investment cast electropolished AISI 316 stainless steel.

Flow rates up to 90 m³/h, heads up to max. 50 m. (5 bar).



CL-CLC pump



CL-CLC pump with shroud

Seals:

Mechanical seals with seats to EN 12756, ISO 3069 standards.

- Single internal mechanical seal
- Single external mechanical seal
- Double flushed mechanical seal

Elastomers (FDA):

- EPDM
- Fluorocarbon (Viton)
- Silicone
- P.T.F.E. (FEP)

Connections:

DIN - SMS - IDF - BS / RJT - DS - CLAMP and EN 1092-1 PN16 flanges suitable for most international standards.

Applications

Food processing, dairy, beverage, chemical, cosmetics and pharmaceutical industries. With an open impeller, juices, creams, ice-cream mix, milk, wine, spirits and whey, can be safely transferred at low pressure. While with a higher efficiency closed impeller, clean liquids without solids can be pumped at medium-high heads (max. 40-50 m) to feed pasteurizers and coolers, concentrators, filters, CIP systems, etc.



Open

Closed in 2 pieces

Closed

All impellers, both closed and open, have reversed blades, designed to optimize the hydraulic efficiency.

CL GENERAL DIAGRAM OPEN IMPELLER

Performance applies to H₂O at 20 °C, 1013 mbar, Data not binding.

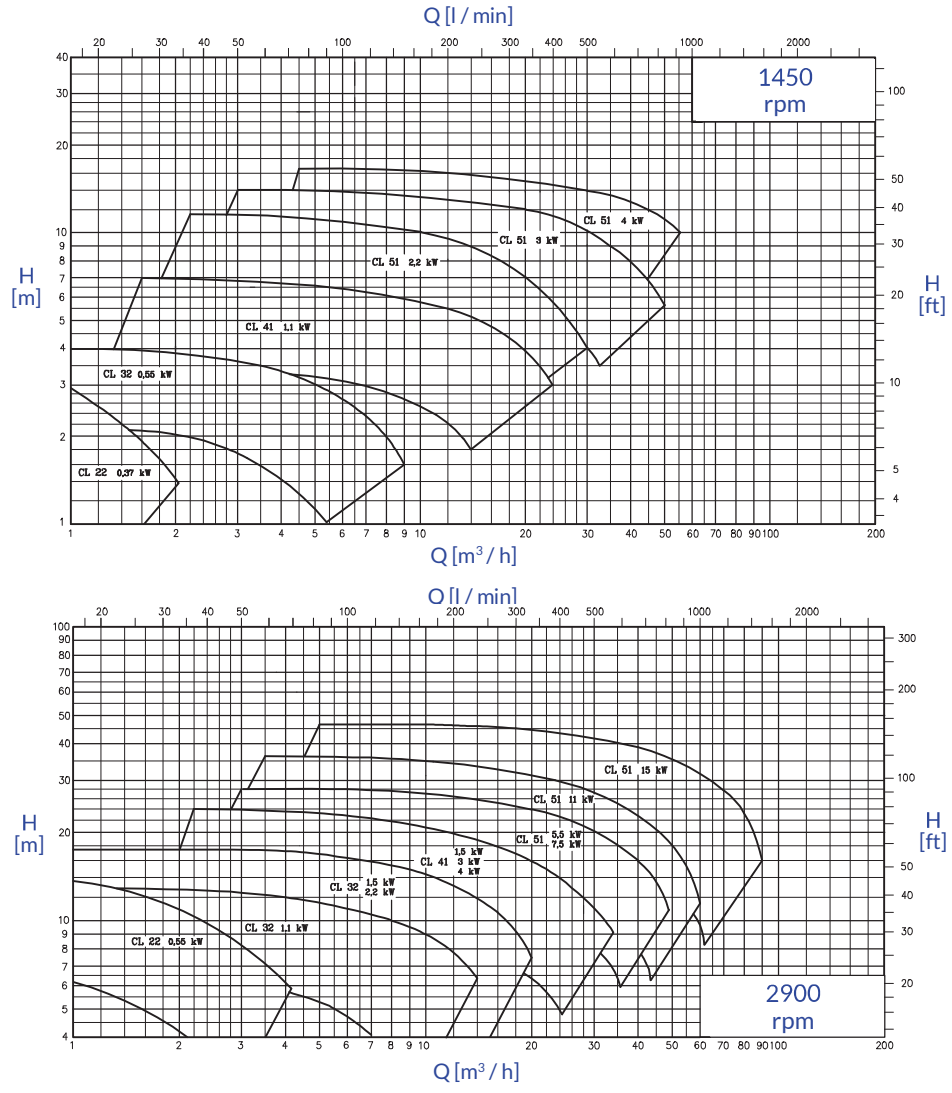

CLC GENERAL DIAGRAM CLOSED IMPELLER

Performance applies to H₂O at 20 °C, 1013 mbar, Data not binding.

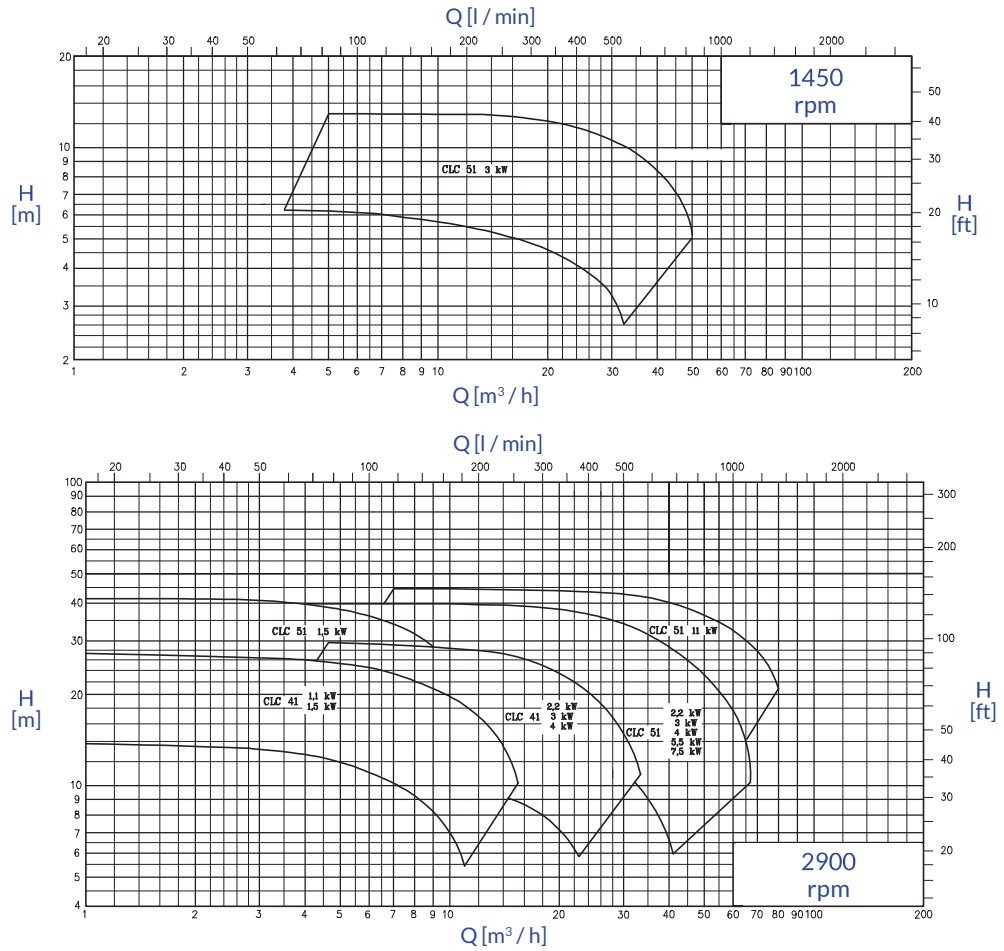

OVERALL DIMENSIONS (INCLUDING SHROUD)

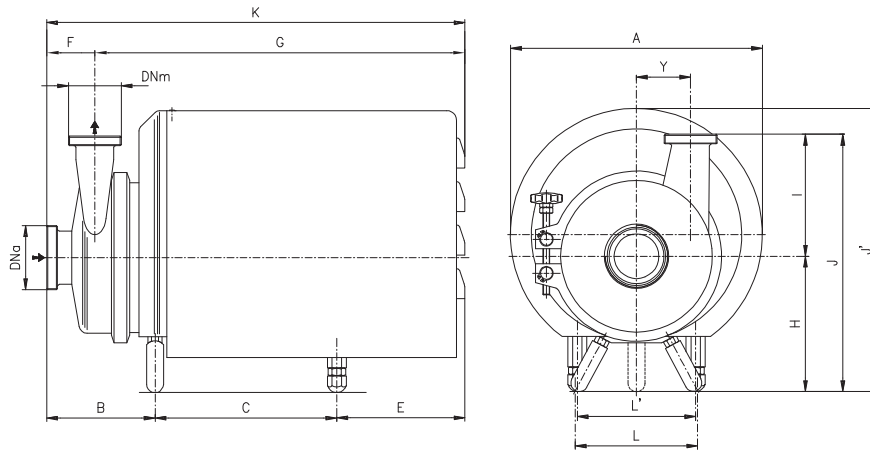

Dimensions not binding - DN = DIN 11851 male threaded connections

Pumps	rpm	kW	DNa	DNm	A	B	C	E	F	G	K	H	I	J	J'	L	L'	Y
CL 22../P	1450	0,37	25	25	212	165	90	138	52	340	392	71	95	166	205	112	136	0
CL 22../P	2900	0,55	25	25	212	165	90	138	52	340	392	71	95	166	205	112	136	0
CL 22../P	2900	0,75	25	25	212	172,5	100	122,5	45	340	392	80	95	175	214	125	155	0

Pumps	rpm	kW	DNa	DNm	A	B	C	E	F	G	K	H	I	J	J'	L	L'	Y
CL 32../P		0,55	40	40	239	120	195	177	51	437,5	479,5	155	125	280	305,8	200	-	40
CL 41../P	1,1	50	40	298	159	168	180	62	445	507	160	150	310	324	190	-	60	
CL 51../P	2,2	65	50	298	154	188	219	66	495	561	165	180	375	359	180	-	80	
	3	65	50	298	173	188	219	72	508	580	195	180	375	359	180	-	80	
	4	80	65	298	177	195	212	76	508	584	195	200	395	359	180	-	70	
CLC 51../P	3	80	65	298	177	188	219	76	508	584	195	200	395	359	180	-	70	
	4	80	65	298	177	188	219	76	508	584	195	200	395	359	180	-	70	

CL 32../P	1,1	32	32	239		205	177	51			155	125	280		200	-	40
	1,5	32	32	239	120	205	177	51	437,5	479,6	155	125	280	305,8	200	-	40
	2,2	40	40	239		235	133	51			155	125	280		200	-	40
CL 41../P	1,5	40	32	298	143	192	152	56	431	487	160	150	310	330	190	-	60
	3	50	40	298	143	217	192	56	496	552	160	150	310	324	168	-	60
	4	50	40	298	143	224	185	56	496	552	160	150	310	324	168	-	60
CL 51../P	5,5	65	50	368	147	228	232	66	541	607	200	180	380	416	178	115	80
	7,5	65	50	368	147	228	232	66	541	607	200	180	380	416	178	115	80
	11	65	50	368	147	211	249	66	541	607	200	180	380	416	178	185	80
	15	80	65	368	170	211	249	74	541	615	200	200	400	416	178	185	70
CLC 41../P	1,1	40	32	298	142	162	186	56	434	490	160	150	310	324	190	-	60
	1,5	40	32	298	142	168	180	56	434	490	160	150	310	324	190	-	60
	2,2	50	40	298	142	193	155	62	434	490	160	150	310	324	190	-	60
	3	50	40	298	151	217	192	62	498	560	160	150	310	324	168	-	60
	4	50	40	298	151	224	185	62	498	560	160	150	310	324	168	-	60
CLC 51../P	1,5	25	25	298	127	165	180	52	420	472	165	160	325	329	152	-	80
	2,2	32	32	298	137	165	180	61	420	481	165	160	325	329	152	-	80
	3	50	40	298	150	188	220	63	495	558	195	160	355	359	180	-	80
	4	50	50	298	161	195	212	66	501	567	195	180	375	359	180	-	80
	5,5	65	50	368	157	228	231	69	547	616	200	180	380	416	178	115	80
	7,5	65	50	368	157	228	231	69	547	616	200	180	380	416	178	115	80
	11	65	65	368	162	211	253	74	552	626	200	200	400	416	178	185	70

OVERALL DIMENSIONS

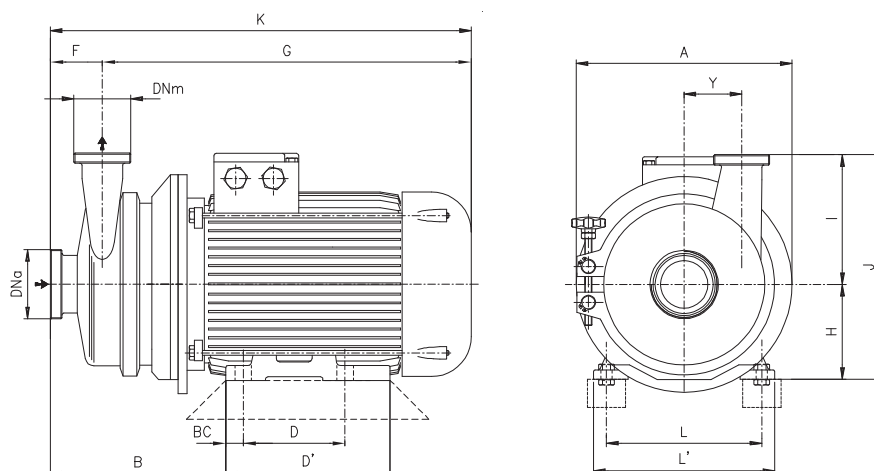

Dimensions not binding - DN = DIN 11851 male threaded connections

Pumps	rpm	kW	DNa	DNm	Ø A	B	BC	D	D'	F	G	K	H	I	J	L	L'	Y
CL 22	1450	0,37	25	25	141	155	10	90	110	52	278	330	71	95	166	112	136	0
CL 22	2900	0,55	25	25	141	155	10	90	110	52	278	330	71	95	166	112	136	0
CL 22	2900	0,75	25	25	141	160	12,5	110	125	52	298	350	80	95	175	125	155	0

Pumps	rpm	kW	DNa	DNm	Ø A	B	BC	D	D'	F	G	K	H	I	J	L	L'	Y
CL 32		0,55	40	40	155	168	12,5	100	118	51	314	365	80	125	205	125	150	40
CL 41	1,1	50	40	200	212	15	100	143	62	391	453	90	150	240	140	165	60	
CL 51	2,2	65	50	254	211	20	140	176	66	415	481	100	180	280	160	196	80	
	3	65	50	254	230	20	140	176	72	428	500	100	180	280	160	196	80	
	4	80	65	254	241	20	140	176	76	449	525	112	200	312	190	226	70	
CLC 51	3	80	65	254	241	18	140	176	76	428	504	100	200	300	160	196	70	
	4	80	65	254	243	18	140	176	76	449	525	112	200	312	190	226	70	

CL 32	1450 rpm	1,1	32	32	155	168	12,5	100	118	51	314	365	80	125	205	125	150	40
		1,5	32	32	155	172	15	100	143	51	362	413	90	125	215	140	165	40
		2,2	40	40	155	172	15	125	143	51	362	413	90	125	215	140	165	40
CL 41	1450 rpm	1,5	40	32	200	195	15	100	143	56	380	436	90	150	240	140	165	60
		3	50	40	250	199	20	140	176	56	413	469	100	150	250	160	196	60
		4	50	40	250	206	20	140	176	56	434	490	112	150	262	190	226	60
CL 51	1450 rpm	5,5	65	50	300	230	24	140	176	68	472	540	132	180	312	216	256	80
		7,5	65	50	300	230	24	140	176	68	472	540	132	180	312	216	256	80
		11	65	50	300	241	20	178	220	66	536	602	132	180	312	216	260	80
		15	80	65	300	249	20	178	220	74	536	610	132	200	432	216	260	70
CLC 41	2900 rpm	1,1	40	32	200	191	12,5	100	118	56	332	388	80	150	230	125	150	60
		1,5	40	32	200	195	15	100	143	56	380	436	90	150	240	140	165	60
		2,2	50	40	200	195	15	125	143	62	380	436	90	150	240	140	165	60
		3	50	40	250	207	20	140	176	62	415	477	100	150	250	160	196	60
CLC 51	2900 rpm	4	50	40	250	214	20	140	176	62	436	498	112	150	262	190	226	60
		1,5	25	25	254	181	15	100	143	52	370	422	90	160	250	140	165	80
		2,2	32	32	254	191	15	125	143	61	370	431	90	160	250	140	165	80
		3	50	40	254	207	20	140	176	63	415	478	100	160	260	160	196	80
CLC 51	2900 rpm	4	50	50	254	224	20	140	176	66	442	508	112	180	272	190	226	80
		5,5	65	50	300	241	24	140	180	72	478	550	132	180	312	216	256	80
		7,5	65	50	300	241	24	140	180	72	478	550	132	180	312	216	256	80
		11	65	65	300	249	20	178	220	74	536	610	132	200	332	216	260	70



A-PF Solutions s.r.l.

+32(0)478 29 26 69

info@apfs.be

www.apfs.be



All the instructions, data and representations (in whatever way executed) listed in this publication are indicative and do not binding. C.S.F. does not stand surety or undertake any obligation for the utilisation of this document and for the information contained. In particular, it does not guarantee against omissions or errors of the data and drawings here indicated. Notice that the technical specifications, information and representations in this document are merely indicative and approximate. C.S.F. INOX reserves the right at any moment and without notice to modify the data, drawings and information indicated in this document.