



Self-Priming Sanitary Pumps



AS series

Standard design

AS series sanitary self-priming pumps.

A close coupled design with independent shaft support and standard IEC motors. The ability of these pump to maintain a vacuum under varying suction conditions, makes them ideal for applications where the incoming liquid contains gas or air, such as vessel scavenging, the handling of foaming liquids or where the suction pipe is only partially flooded. Prior to the first start-up, they must be initially filled with liquid; subsequently, liquid remains in the pump, allowing rapid self-priming to occur, even if the suction pipe is emptied.

The construction materials and the quick disassembly design make the AS series particularly suitable for a wide range of applications.

All CF-3M 1.4404 / AISI 316L stainless steel parts.

Investment cast components with electro-chemical polishing.

Stainless steel adjustable feet.



AS single-stage pump



AS 2-stage pump

Seals:

Mechanical seals with seats to EN 12756, ISO 3069 standards.

- Single internal mechanical seal
- Flushed mechanical seal
- Double flushed mechanical seal

Elastomers (FDA):

- EPDM
- Fluorocarbon (Viton)
- Silicone
- P.T.F.E. (FEP)
- FFPM

Connections:

DIN - SMS - IDF - BS / RJT - DS - CLAMP and EN 1092-1 PN16 flanges to suit most international standards.

Applications

AS series pumps incorporate design features and material technologies that enable them to fulfil a wide range of operational requirements within the food, beverage, dairy, pharmaceutical and chemical industries. They are especially suited for clear low viscosity fluids: CIP solutions, water, juices, wine, spirits, chemicals and pharmaceutical media, in CIP scavenge/return and tank emptying duties.



A range of 4 single-stage and 2 two-stage versions.

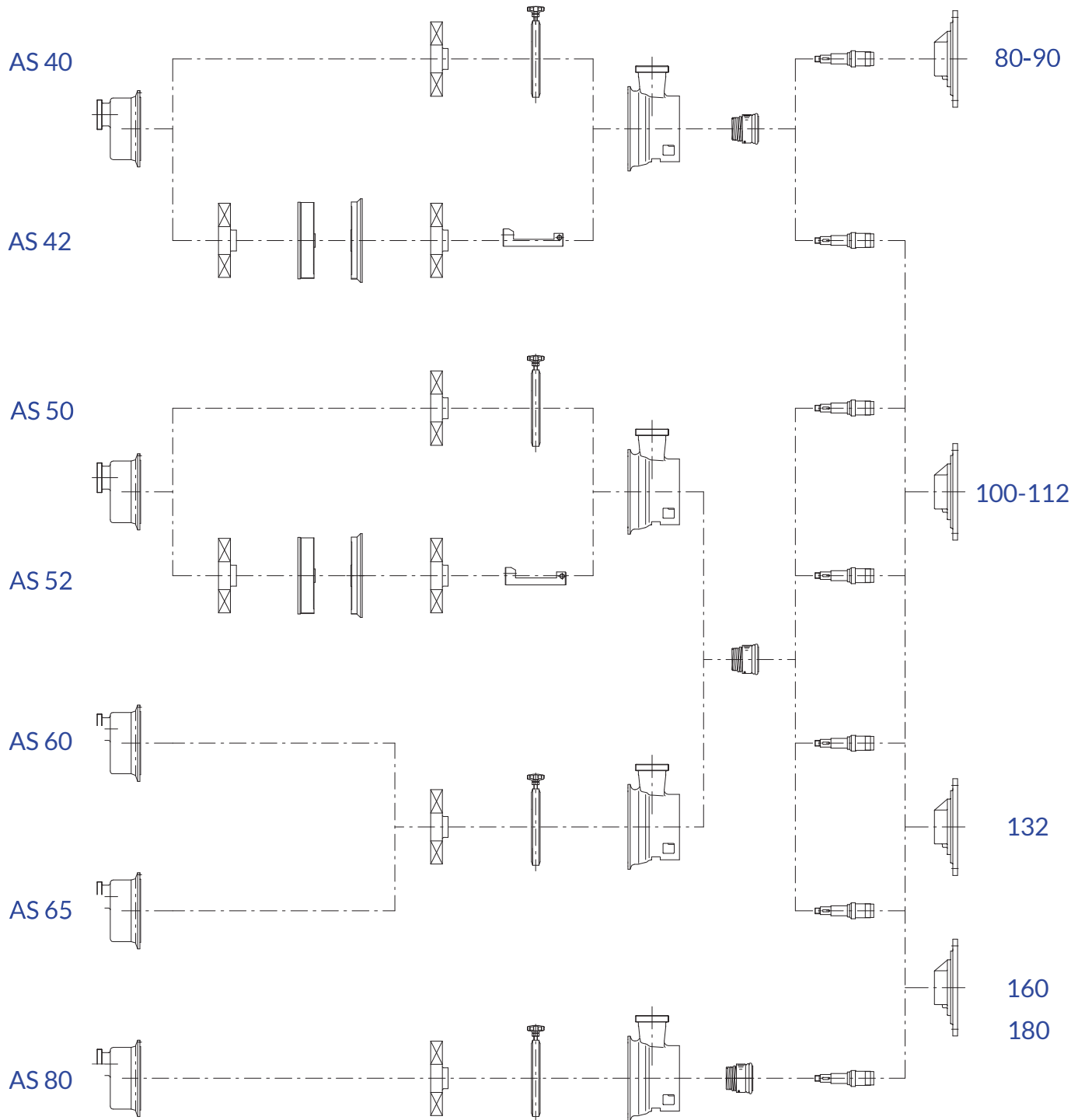

Star-shaped impellers in CF-3M 1.4404 / AISI 316L stainless steel achieved with micro-casting procedure.



GENERAL DIAGRAM - 50 Hz

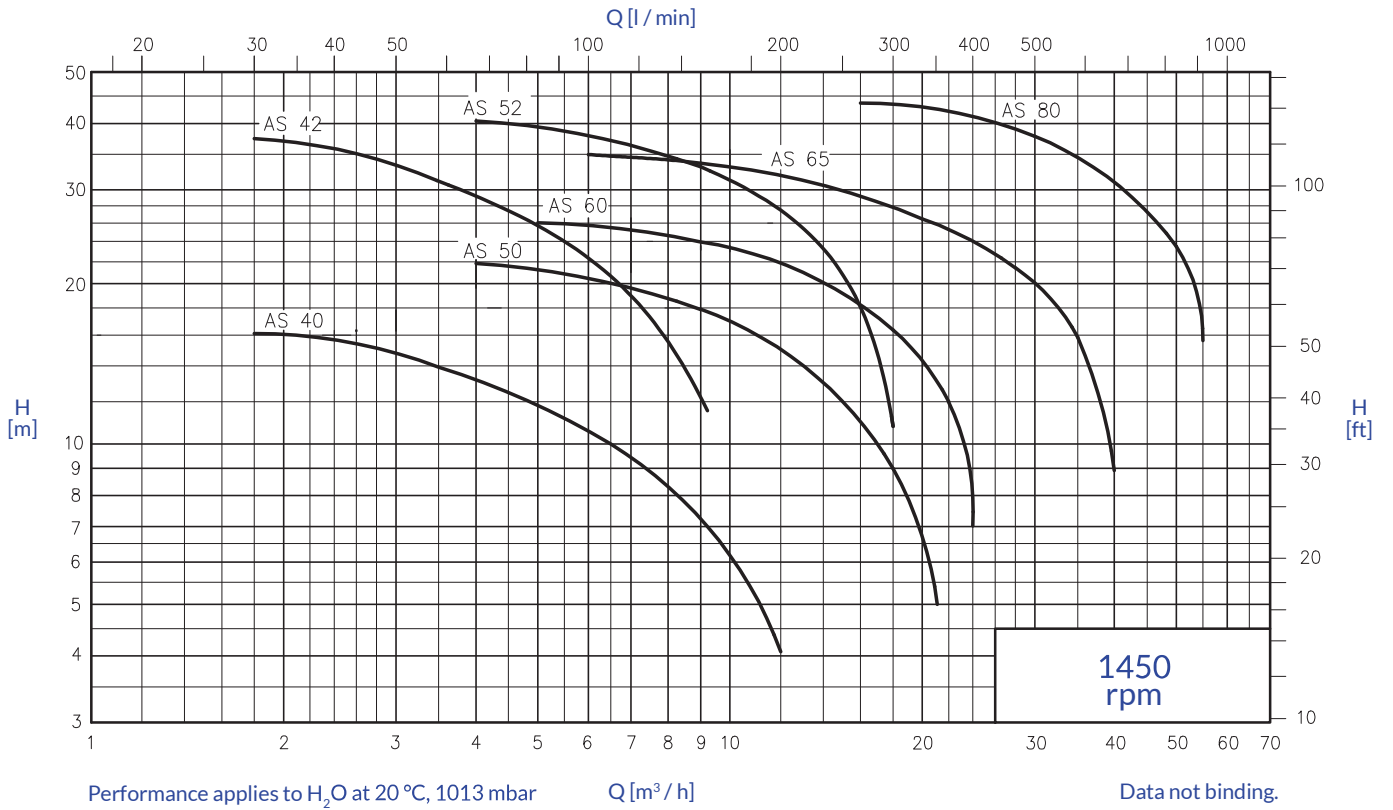

GENERAL DIAGRAM - 60 Hz

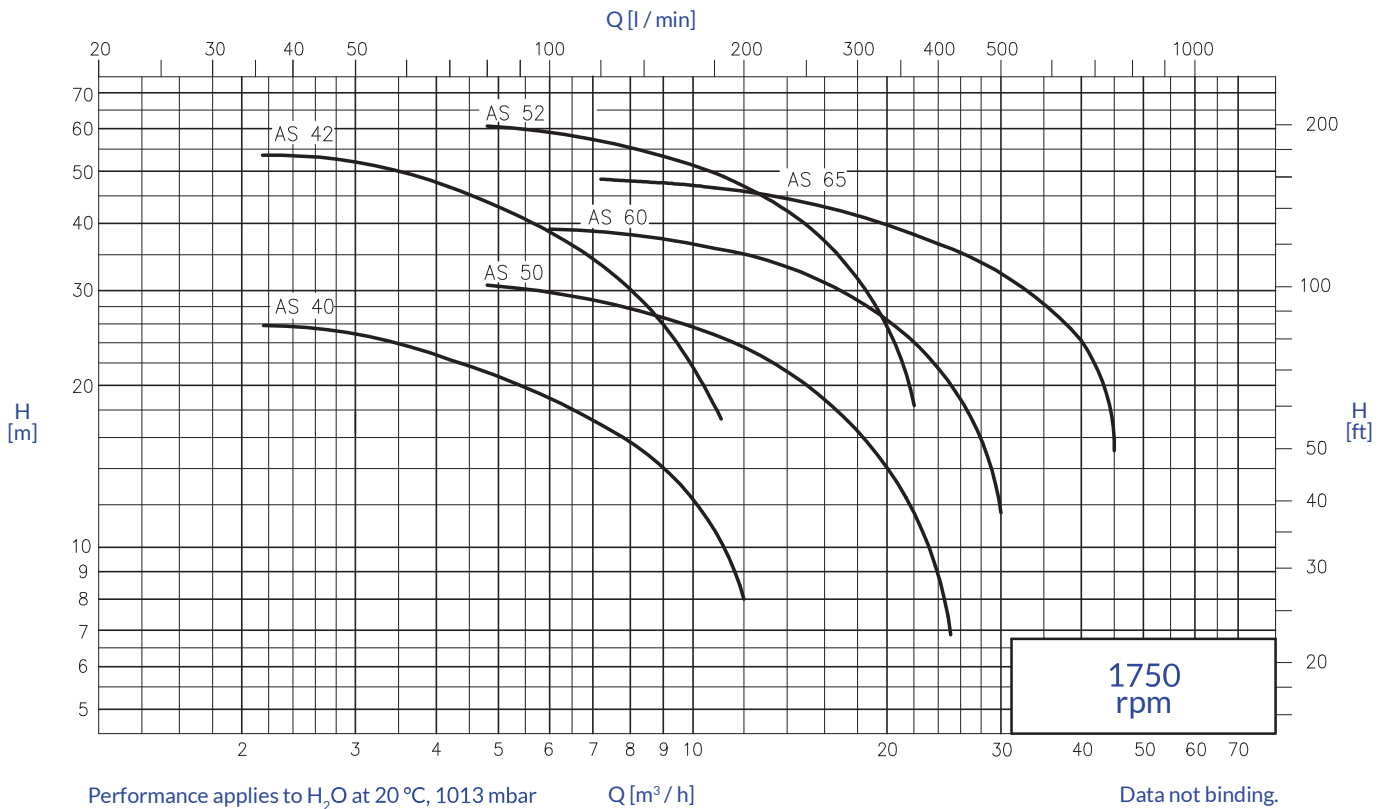

OVERALL DIMENSIONS

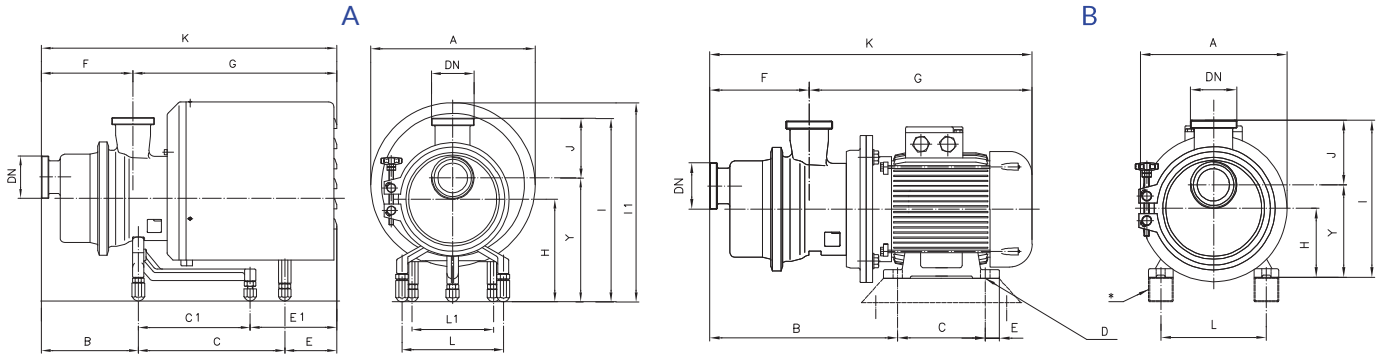

A = with shroud

Dimensions not binding - DN = DIN 11851 male threaded connections, with standard IEC/EN motors

Pumps	kW	DN	A	B	C	C1	E	E1	F	G	K	H	J	I	I1	Y	L	L1
AS 40	1,1	40	238	167	-	190	-	219	141	435	576	162	110	307	299	197	178	-
	1,5	40	238	167	-	190	-	219	141	435	576	162	110	307	299	197	178	-
	2,2	40	330	167	-	301	-	183	141	510	651	190	110	335	395	225	225	-
AS 50	2,2	50	330	196	-	301	-	202	175	523	697	228	114	378	433	264	225	-
	4	50	330	196	-	301	-	202	175	523	697	228	114	378	433	264	225	-
AS 60	4	65	330	216	-	301	-	202	211	514	719	228	135	408	433	273	225	-
	5,5	65	370	216	267	-	224	-	211	557	762	228	135	408	450	273	225	180
AS 65	5,5	65	370	216	267	-	224	-	211	557	762	228	135	408	450	273	225	180
	7,5	65	370	216	267	-	224	-	211	557	762	228	135	408	450	273	225	180
AS 80	11	80	430	267	375	-	347	-	248	848	1096	228	160	446	491	286	225	230
	15	80	430	267	375	-	347	-	248	848	1096	228	160	446	491	286	225	230

* Motor shims on request

B = without shroud

Dimensions not binding - DN = DIN 11851 male threaded connections, with standard IEC/EN motors

Pumps	kW	DN	A	B	C	øD	E	F	G	K	H	J	I	Y	L	M	N	O
AS 40	1,1	40	200	296	100	10	34	141	380	521	90	110	235	125	140	-	-	-
	1,5	40	200	296	125	10	9	141	380	521	90	110	235	125	140	-	-	-
	2,2	40	250	308	140	12	18	141	416	557	100	110	245	135	160	-	-	-
AS 50	2,2	50	250	343	140	12	18	175	419	594	100	114	250	136	160	-	-	-
	4	50	250	351	140	12	18	175	441	616	112	114	262	148	190	-	-	-
AS 60	4	65	250	372	140	12	18	211	431	636	112	135	292	157	190	-	-	-
	5,5	65	300	412	140	12	20	211	492	697	132	135	312	177	216	-	-	-
AS 65	5,5	65	300	412	140	12	20	211	492	697	132	135	312	177	216	-	-	-
	7,5	65	300	412	178	12	20	211	492	697	132	135	312	177	216	-	-	-
AS 80	11	80	350	555	210	15	23	248	677	925	160	160	378	218	254	-	-	-
	15	80	350	555	254	15	23	248	677	925	160	160	378	218	254	-	-	-

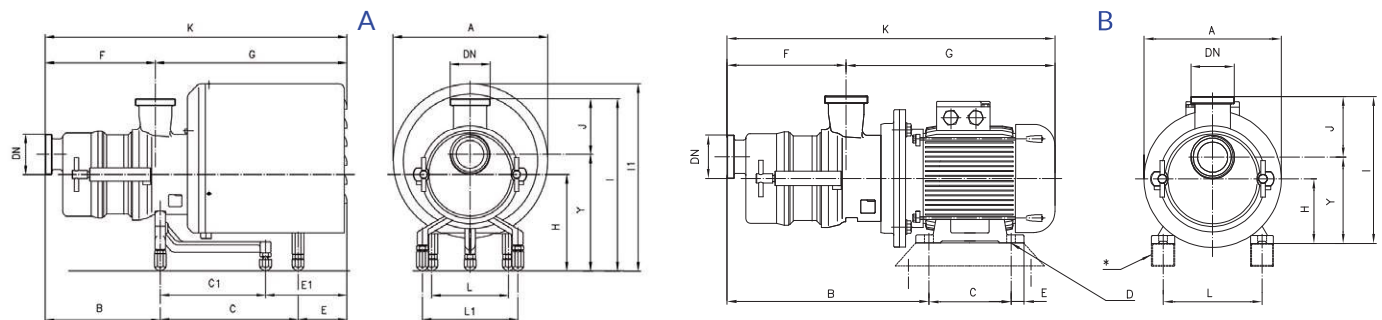

A = with shroud

Dimensions not binding - DN = DIN 11851 male threaded connections, with standard IEC/EN motors

Pumps	kW	DN	A	B	C	C1	E	E1	F	G	K	H	J	I	I1	Y	L	L1
AS 42	2,2	40	330	226	-	301	-	183	200	510	710	190	110	335	395	225	225	-
	3	40	330	226	-	301	-	183	200	510	710	190	110	335	395	225	225	-
AS 52	5,5	50	370	258	266	-	280	-	237	567	804	228	114	378	450	264	225	180

* Motor shims on request

B = without shroud

Dimensions not binding - DN = DIN 11851 male threaded connections, with standard IEC/EN motors

Pumps	kW	DN	A	B	C	øD	E	F	G	K	H	J	I	Y	L	M	N	O
AS 42	2,2	40	250	365	140	12	18	200	416	616	100	110	245	135	160	-	-	-
	3	40	250	365	140	12	18	200	416	616	100	110	245	135	160	-	-	-
AS 52	5,5	50	300	454	140	12	20	237	502	739	132	115	282	168	216	-	-	-



A-PF Solutions s.r.l.

+32 (0)478 29 26 69

info@apfs.be

www.apfs.be



All the instructions, data and representations (in whatever way executed) listed in this publication are indicative and do not binding. C.S.F. does not stand surety or undertake any obligation for the utilisation of this document and for the information contained, in particular, it does not guarantee against omissions or errors of the data and drawings here indicated. Notice that the technical specifications, information and representations in this document are merely indicative and approximate. C.S.F. INOX reserves the right at any moment and without notice to modify the data, drawings and information indicated in this document.