



Self-priming pumps



A series

Standard design

Self-priming pumps.

The ability to maintain a vacuum under changing suction conditions makes A Series pumps ideally suited for scavenge duties and applications where the inlet pipework is only partially filled, or where the incoming liquid includes entrained air or gas. The construction materials and quick disassembly design make them particularly suitable for a wide variety of applications.

They must be initially filled with liquid for the first start-up; afterwards, a small liquid reservoir remains to enable rapid self-priming to occur even if the suction pipe is emptied.

A 21- A 31: Close-coupled pumps with the impeller directly supported by the electric motor shaft. Easy-opening front cover, by unscrewing three hand-nuts, allows quick inspection without disconnecting the inlet and outlet pipes.

A 41 - A 51 - A 66 - A 81: Close-coupled design with separate IEC motor and flexible coupling. Easy-opening front cover, for quick inspection without disturbing the inlet and outlet pipes.

All CF-8M 1.4408 / AISI 316 Stainless steel parts.

Investment cast, with electro-chemical polishing.

Flow rates up to 50 m³/h, heads up to max. 35 m (3,5 bar) (50 Hz).



A 21 - A31 pump



A 41 - A 51 pump



A 41 - A 51 pump with shroud

Seals:

Mechanical seals with seats to EN 12756. ISO 3069 standards.
Single internal mechanical seal
Single external mechanical seal

Elastomers (FDA):

EPDM
Fluorocarbon (Viton)
P.T.F.E. (FEP)

Connections:

DIN - SMS - IDF - BS / RJT - DS - CLAMP and EN 1092-1 PN16 flanges to suit most international standards.

Applications

A Series pumps are suitable for a wide range of liquids (CIP solutions, juices, milk, whey, syrups, oil, wine, water, spirits, chemical and pharmaceutical media).



GENERAL DIAGRAM - 50 Hz

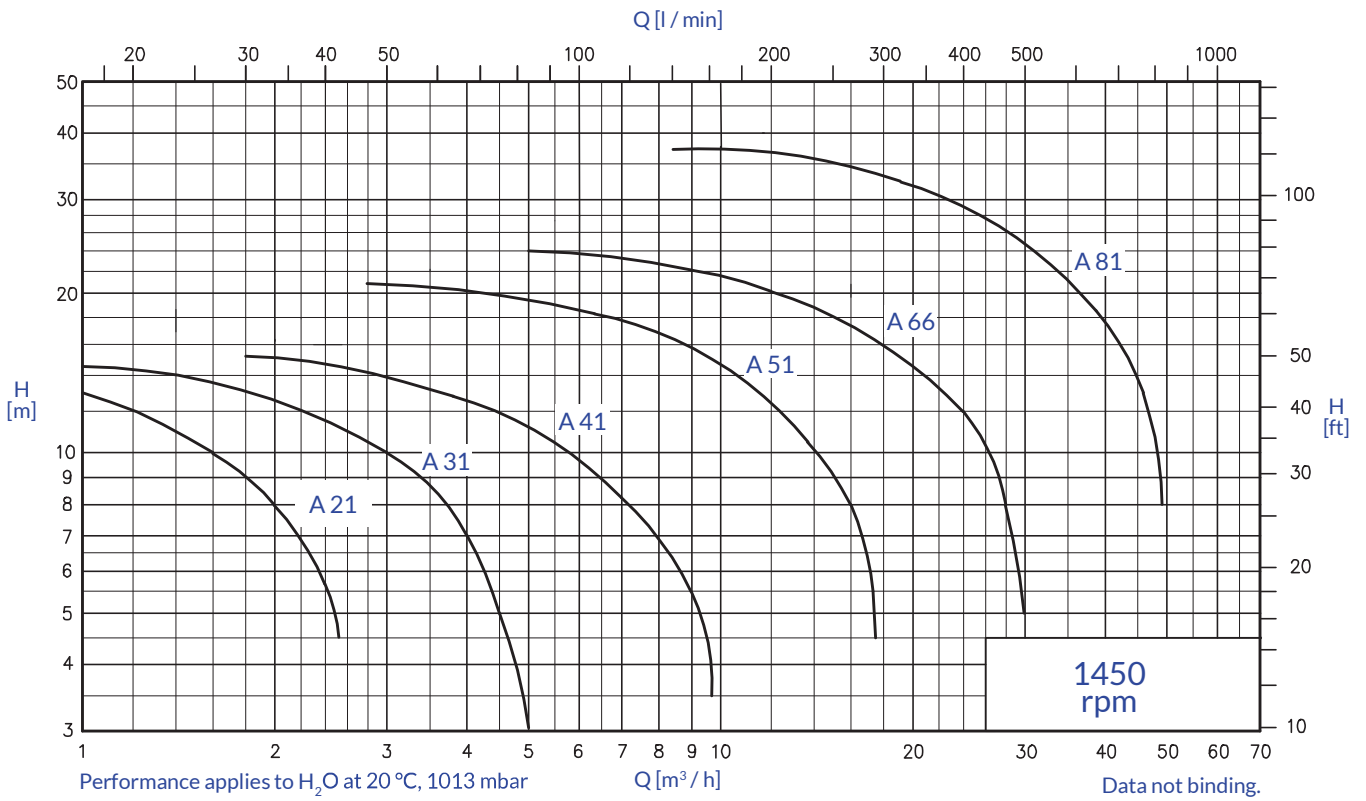

GENERAL DIAGRAM - 60 Hz

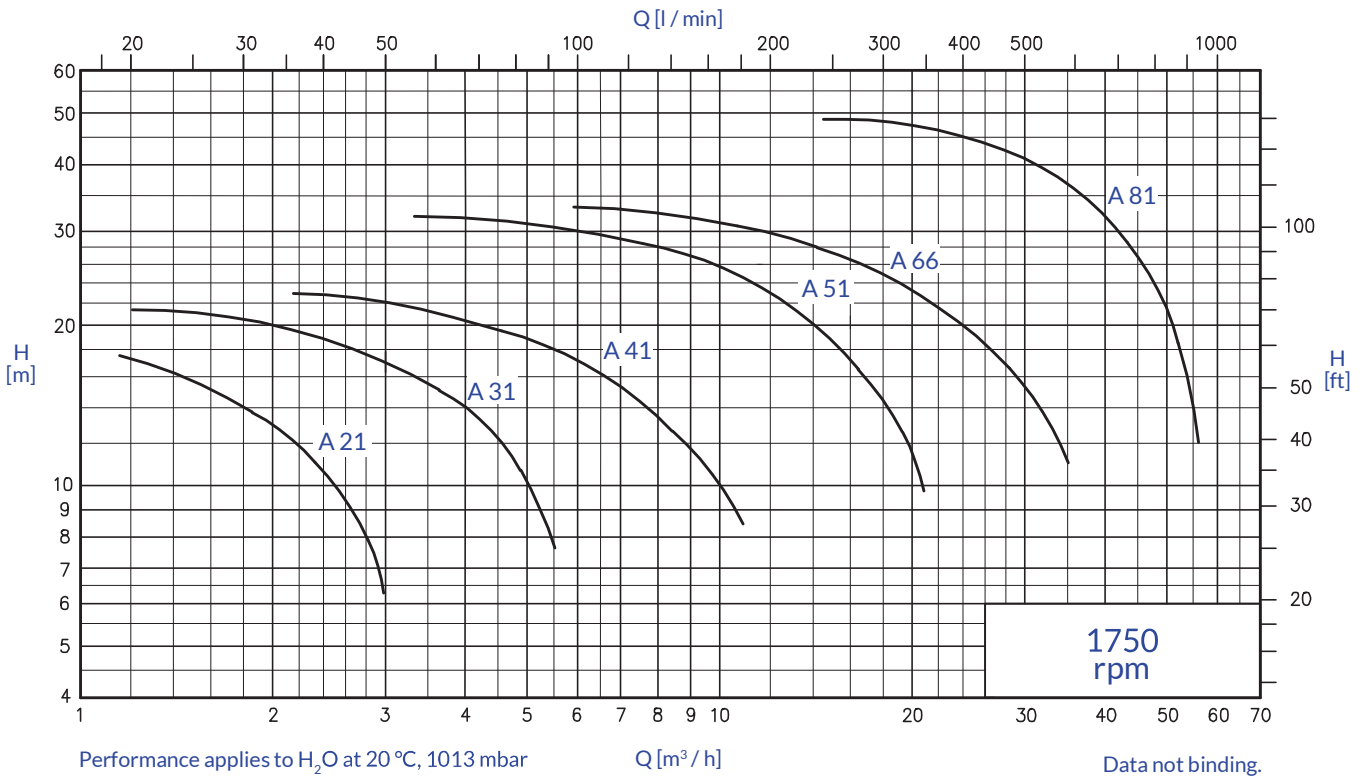

OVERALL DIMENSIONS

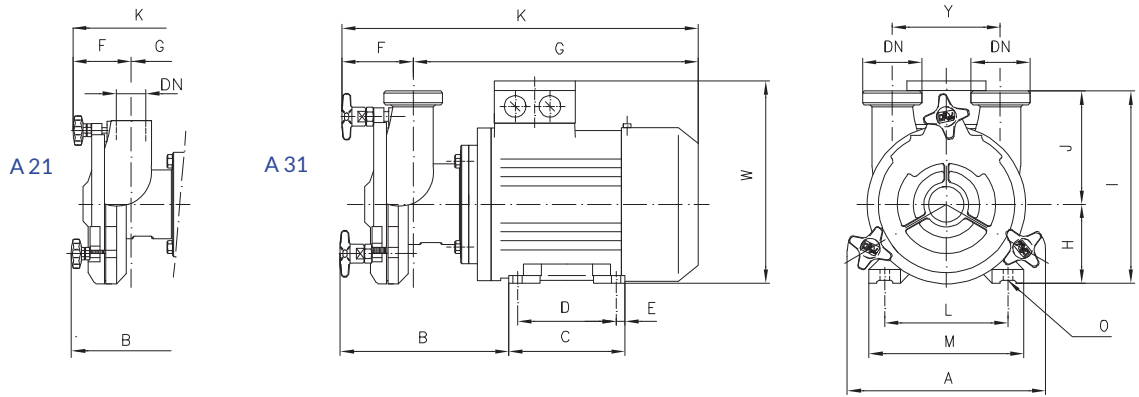

Dimensions not binding - DN = GAS (BSP female) connection on A21
 DN = DIN 11851 male threaded connection for A31

Pumps	1450 rpm.	kW	DN	A	B	C	D	E	F	G	K	H	J	I	Y	L	M	O	P	Q	W
A 21	1450 rpm.	0,37	3/4"G	170	149	106	90	8	62	268	330	71	84	155	80	112	132	7	-	-	192
		0,55	3/4"G	170	152	118	100	9	62	286,5	348,5	80	84	164	80	125	150	9	-	-	210
A 31	1450 rpm.	0,55	32	203	175	118	100	9	75	295,5	370,5	80	117	197	110	125	150	9	-	-	210
		0,75	32	203	175	118	100	9	75	295,5	370,5	80	117	197	110	125	150	9	-	-	210

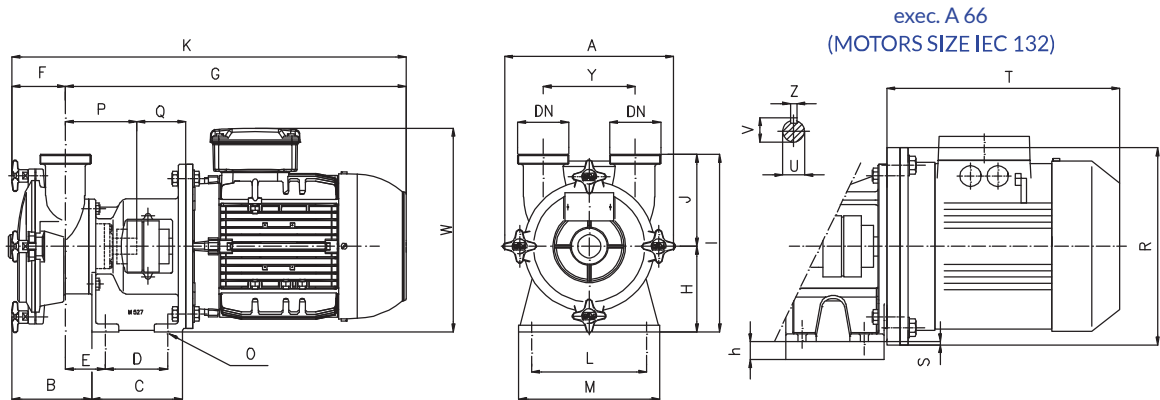

Dimensions not binding - DN = DIN 11851 male threaded connections with standard IEC/EN motors
 (*) Bearing frame designed for direct coupling with motor frame ...

Pumps	1450 rpm	kW	DN	A	B	C	D	E	F	G	K	H	h	J	I	Y	L	M	O	P	Q	R	S	T	U	V	W	Z	PAM(*)
A 41	1450 rpm	1,1	40	250	116	132	89	53,5	79	452	531	122	-	120	242	120	135	175	12	117	54	-	-	-	20	22,5	272	6	90
		1,5	40	250	116	132	89	53,5	79	452	531	122	-	120	242	120	135	175	12	117	54	-	-	-	20	22,5	272	6	90
A 51	1450 rpm	2,2	50	273	127	138	95	59,5	88	499	587	130	-	140	270	140	175	215	12	119	64	-	-	-	20	22,5	290	6	100
		4	50	273	127	138	95	59,5	88	521	609	130	-	140	270	140	175	215	12	119	64	-	-	-	20	22,5	284	6	112
A 66	1450 rpm	4	65	307	182	150	95	74	133	540	673	145	-	185	330	180	190	230	12	137	65	-	-	-	25	28	299	8	112
		5,5	65	307	182	150	95	74	133	600	732	145	15	185	330	180	190	230	12	137	65	300	5	393	25	28	299	8	132

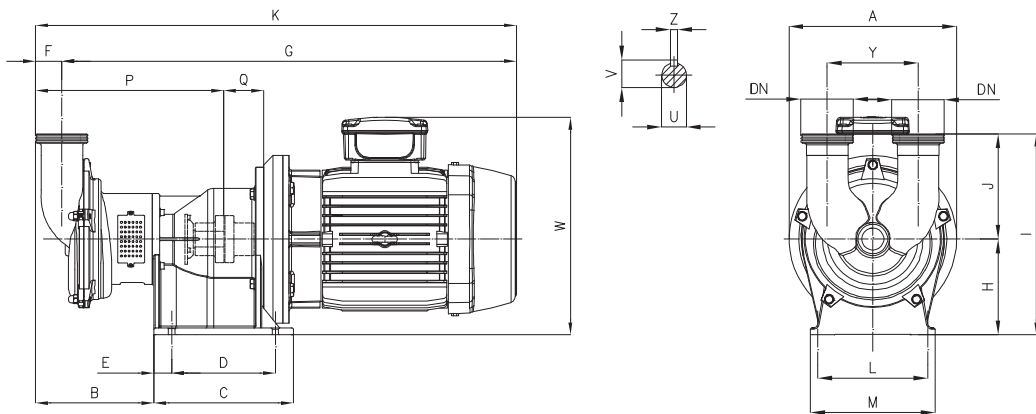

Dimensions not binding - DN = DIN 11851 male threaded connections with standard IEC/EN motors
 (*) Bearing frame designed for direct coupling with motor frame ...

Pumps	1450 rpm	kW	DN	A	B	C	D	E	F	G	K	H	J	I	Y	L	M	O	P	Q	U	V	W	Z	PAM(*)
A 81	1450 rpm	9,2	80	326	247	292	214	233	55	833	888	200	220	420	190	230	260	14	339	83	32	35	406,5	10	132
		11	80	350	247	292	214	233	55	994	1049	200	220	420	190	230	260	14	339	123	32	35	464	10	160
		15	80	350	247	292	214	233	55	994	1049	200	220	420	190	230	260	14	339	123	32	35	464	10	160

OVERALL DIMENSIONS (INCLUDING SHROUD)

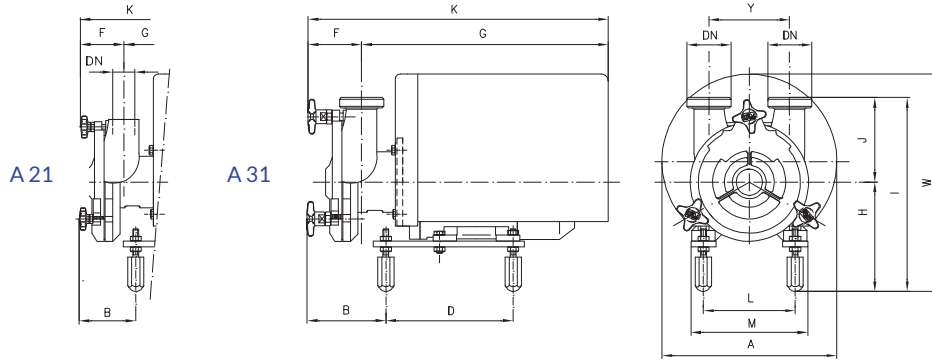

Dimensions not binding - DN = GAS (BSP female) connection on A21
 DN = DIN 11851 male threaded connection for A31

Pumps	1450 rpm	kW	DN	A	B	C	D	E	F	G	K	H	J	I	Y	L	M	O	P	Q	W
A 21	0,55	3/4"G	238	88	-	173	-	62	336	398	153	85	238	80	125	150	-	-	-	-	301
A 31	0,55	32	238	111	-	173	-	75	334	409	153	117	270	110	125	150	-	-	-	-	301
	0,75	32	238	111	-	173	-	75	334	409	153	117	270	110	125	150	-	-	-	-	301

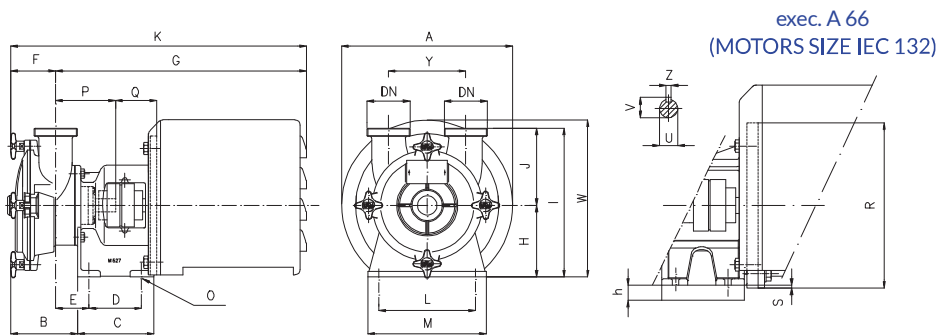

Dimensions not binding - DN = DIN 11851 male threaded connections with standard IEC/EN motors
 (*) Bearing frame designed for direct coupling with motor frame ...

Pumps	1450 rpm	kW	DN	A	B	C	D	E	F	G	K	H	h	J	I	Y	L	M	O	P	Q	R	S	U	V	W	Z	PAM (*)
A 41	1,1	40	297	116	132	89	53,5	79	549	631	122	-	120	242	120	135	175	12	117	51	-	-	20	22,5	313	6	90	
	1,5	40	297	116	132	89	53,5	79	549	631	122	-	120	242	120	135	175	12	117	51	-	-	20	22,5	313	6	90	
A 51	2,2	50	333	127	138	95	59,5	88	607	704	130	-	140	270	140	175	215	12	119	61	-	-	20	22,5	337	6	100	
	4	50	333	127	138	95	59,5	88	607	704	130	-	140	270	140	175	215	12	119	61	-	-	20	22,5	337	6	112	
A 66	4	65	369	182	150	95	74	133	667	800	145	-	185	330	180	190	230	12	137	62	-	-	25	28	360	8	112	
	5,5	65	369	182	150	95	74	133	667	800	145	15	185	330	180	190	230	12	137	62	300	5	25	28	360	8	132	

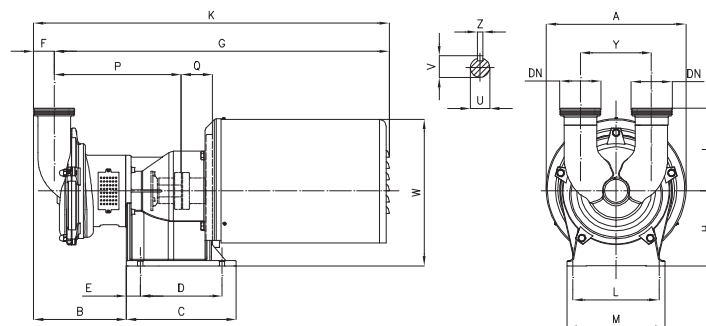

Dimensions not binding - DN = DIN 11851 male threaded connections with standard IEC/EN motors
 (*) Bearing frame designed for direct coupling with motor frame ...

Pumps	1450 rpm	kW	DN	A	B	C	D	E	F	G	K	H	J	I	Y	L	M	O	P	Q	U	V	W	Z	PAM (*)
A 81	9,2	80	432	247	292	214	233	55	1036	1090	200	220	420	190	230	260	14	339	83	32	35	434	10	132	
	11	80	432	247	292	214	233	55	1036	1090	200	220	420	190	230	260	14	339	123	32	35	475	10	160	
	15	80	432	247	292	214	233	55	1036	1090	200	220	420	190	230	260	14	339	123	32	35	475	10	160	



A-PF Solutions s.r.l.

+32(0)478 29 26 69

info@apfs.be

www.apfs.be



All the instructions, data and representations (in whatever way executed) listed in this publication are indicative and do not binding. C.S.F. does not stand surety or undertake any obligation for the utilisation of this document and for the information contained, in particular, it does not guarantee against omissions or errors of the data and drawings here indicated.
 Notice that the technical specifications, information and representations in this document are merely indicative and approximate. C.S.F. INOX reserves the right at any moment and without notice to modify the data, drawings and information indicated in this document.