



Vertical progressive cavity pumps MAV series



 **A-PF SOLUTIONS[®]**
Quality first





The MAV series progressive cavity pumps are designed for vertical operation with the inlet immersed in the product. The range consists of the following models, MAV 40, 50, 60L, 65, 70L, 80, 90L manufactured in stainless steel AISI 316.

MAV Series pumps are intended for product transfer and drum or container emptying applications, in which the suction port is plunged directly into the product.

As standard, MAV pumps have a suction to discharge port dimension of 1100 - 1400 mm. On request, this distance can be personalised to suit a customer's requirements.

It can be mounted on a drum-holding trolley, with a choice of either a manual sliding or an alternative pneumatic lift and lower system.

The operating characteristics and construction materials of these pumps enable the MAV series to be used with many different fluids, from low to high viscosity, including many abrasive and corrosive media. An added benefit is the ability to handle fluids containing fibres or solid materials in suspension.

The main components of the MAV series pumps, such as the stator, rotor, joints and mechanical seal are the same as used on the corresponding horizontal version.

CHARACTERISTICS OF MAV PUMPS

- constant, delicate flow without pulses
- absence of suction valves
- self-priming
- low noise level
- wide range of motor drives with fixed or variable speed

VERSIONS

h = Head, bar Q = Flow rate, m³/h Na = Power, HP n = rpm

Size	Stages	h	n=200		n=300		n=400		n=500		n=600	
			Q	Na	Q	Na	Q	Na	Q	Na	Q	Na
40	1	1					0,6	0,35	0,8	0,35	1	0,35
		3					0,3	0,35	0,5	0,35	0,7	0,4
		6									0,2	0,45
	2	9							0,3	0,6	0,5	0,7
		12									0,3	0,9
50	1	1	0,9	0,6	1,5	0,6	2	0,6				
		3	0,8	0,8	1,3	0,9	1,8	1				
		6	0,6	0,9	1,1	1,1	1,6	1,1				
	2	9	0,2	1,1	0,9	1,2	1,6	1,6				
		12	-	-	0,4	1,3	1,2	1,8				
60	L	2	2,5	1,2	3,7	1,3	5	1,4				
		4	2,3	1,5	3,5	1,7	4,7	1,8				
		6	2	1,7	3,1	1,9	4,2	2,1				
65	1	1	2,5	1,1	3,8	1,1	5	1,4				
		3	2,3	1,2	3,6	1,2	4,5	1,6				
		6	1,7	1,5	2,8	1,7	4	2,1				
	2	9	1	2,8	2,6	3,3	4,1	3,7				
		12	0,3	3	1,6	3,4	3,6	3,9				
70	L	2	5,4	2	8	2,3	10,6	2,8				
		4	5	2,30	7,6	3	10,3	3,7				
		6	4,6	2,8	7,2	3,7	9,8	4,6				
80	1	1	4,7	2,2	7,5	2,5						
		3	4,4	2,5	7	3						
		6	3,8	2,9	6,4	3,5						
90	L	2	13,4	3,5	20,5	4,1						
		4	12,2	4,1	19	5,3						
		6	10,8	5,2	17,2	6,5						

There is a version with suction port in two pieces. This is in order to achieve alternative solutions relating to various uses and the need to perform CIP washing at the end of the cycle.

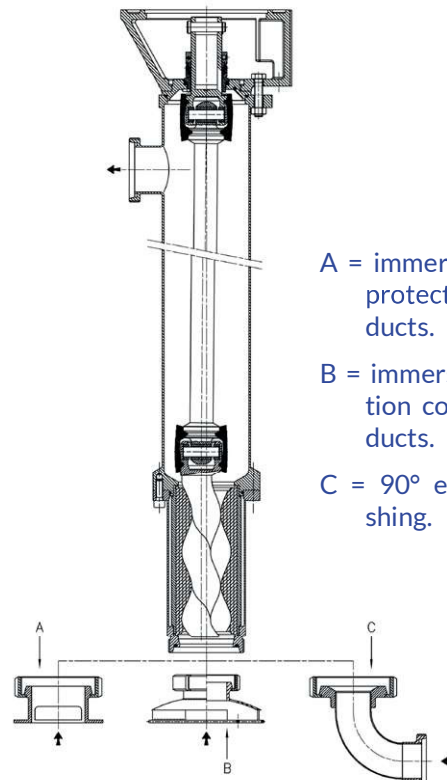

A = immersed port with bag protection for fluid products.

B = immersed port with suction cone for dense products.

C = 90° elbow for CIP washing.

VARIOUS OPTIONS



MAV progressive cavity pump with manual vertical counterweight hoist.

MAV progressive cavity pump with pneumatic vertical hoist and electropneumatic control panel.



MAV progressive cavity pump with rotating table, pneumatic column and control panel.

Overall dimensions

Dimensions not binding

Pump type	DN	D	E	F	F'	G	H	H'	J	K	L	N	S
MAV 40-1	40	-	-	1103	-	126	70	-	79	1229	-	-	-
MAV 50-1	50	92	-	1086	-	198	100	-	86	1284	110	150	17
MAV 50-2	50	92	-	1236	-	198	100	-	86	1434	110	150	17
MAV 60-L	50	92	-	1255	1273	198	100	220	86	1453	110	150	17
MAV 65-1	65	111	-	1103	1142	226	130	220	113	1329	140	180	19
MAV 65-2	65	111	-	1303	1342	226	130	220	113	1529	140	180	19
MAV 70-L	65	111	-	1303	1342	226	130	220	113	1529	140	180	19
MAV 80-1	80	115	5	1104	1124	221	150	275	119,5	1325	150	190	19
MAV 80-2	80	115	5	1354	1374	221	150	255	119,5	1575	150	190	19
MAV 90-L	80	115	5	1243	1251	221	155	275	119,5	1644	150	190	19

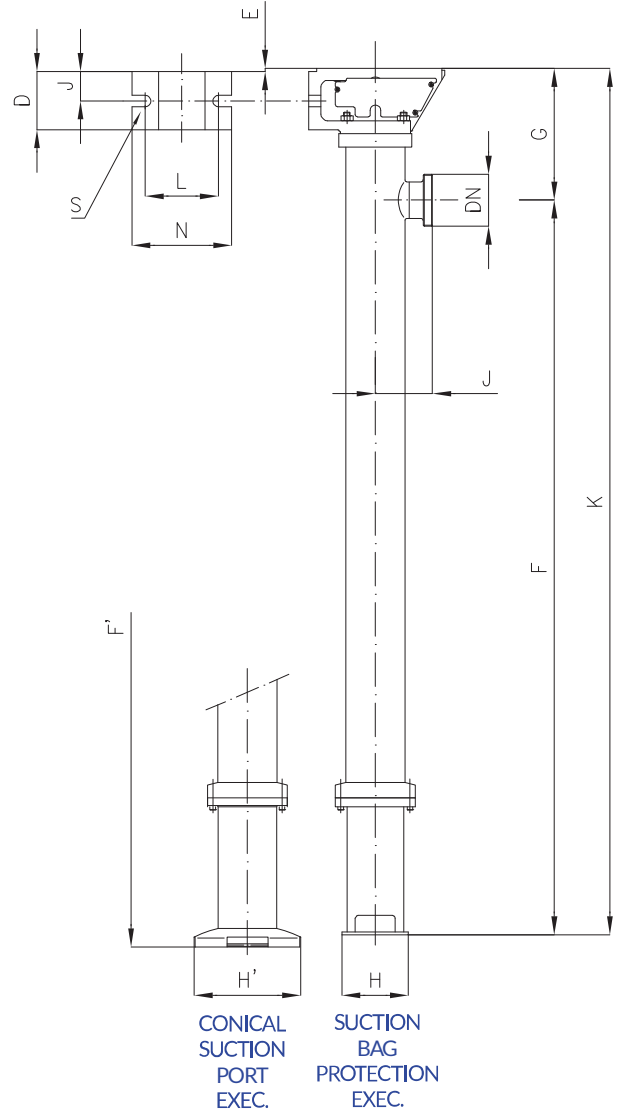

Pump type	A	BH7	C	UH7
MAV 40-1	20	8	=	19
MAV 50-1	25	10	10	24
MAV 50-2	25	10	10	24
MAV 60-L	25	10	10	24
MAV 65-1	25	14	10	32
MAV 65-2	25	14	10	32
MAV 70-L	25	14	10	32
MAV 80-1	26	16	10	35
MAV 80-2	26	16	10	35
MAV 90-L	26	16	10	35

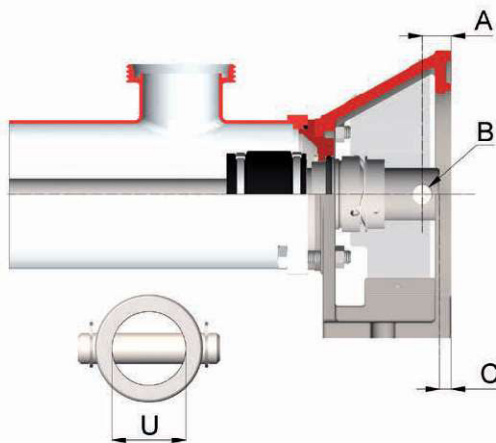

A-PF Solutions s.r.l.

+32(0)478 29 26 69

info@apfs.be

www.apfs.be

All the instructions, data and representations (in whatever way executed) listed in this publication are indicative and do not binding. C.S.F. does not stand surety or undertake any obligation for the utilisation of this document and for the information contained. In particular, it does not guarantee against omissions or errors of the data and drawings here indicated. Notice that the technical specifications, information and representations in this document are merely indicative and approximate. C.S.F. INOX reserves the right at any moment and without notice to modify the data, drawings and information indicated in this document.